

ELEBOR[®]

ELEBOR S.A.

HELLENIC GEOTECHNICAL EQUIPMENT

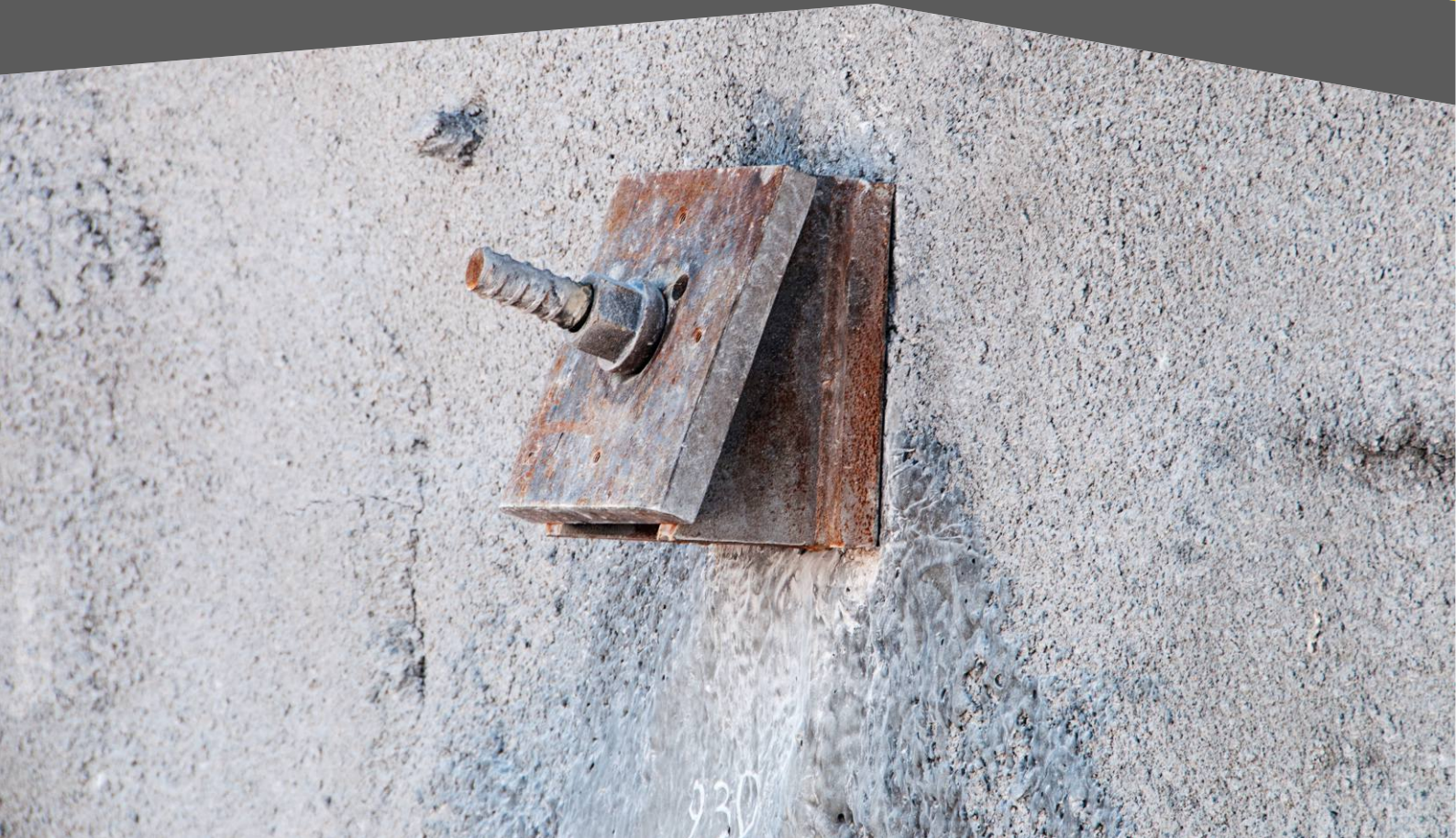

Catalogue
Thread Bar Anchoring System

Edition 2023



ELEBAR[™]
G

Rock bolting - Anchoring systems

Boring - Drilling - Tunnelling - Mining - Construction - Geotechnical





**a complete rock-bolting system
to ensure long-term safety**

Table of Content



Introduction	4
ELEBAR™-G thread bar features	5
Applications	6
ELEBAR™-G steel grades	8
ELEBAR™-G cement grouted rock-bolts (SN-anchors)	10
ELEBAR™-G mechanical anchors (expansion shell anchors)	11
ELEBAR™-G resin rock-bolts/anchors	12
ELEBAR™-G combination bolts (Combi-Bolts CBE/CBR)	13
ELEBAR™-G temporary soil nails (SCP)	14
ELEBAR™-G permanent soil nails (DCP)	15
ELEBAR™-G temporary ground anchors (SCP)	16
ELEBAR™-G permanent ground anchors (DCP)	17
ELEBAR™-G temporary micropiles (SCP)	18
ELEBAR™-G permanent micropiles (DCP)	19
ELEBAR™-G system components - Hexagonal nuts	20
ELEBAR™-G system components - Couplers	22
ELEBAR™-G system components - Ring nuts / Expansion shells	23
ELEBAR™-G system accessories - Anchorage components	24
ELEBAR™-G system accessories - Corrugated sheathing	25
ELEBAR™-G system accessories - Thermoshrinking sheathing	26
ELEBAR™-G system accessories - Smooth sheathing	27
ELEBAR™-G system accessories - External centralizers	28
ELEBAR™-G accessories - Internal / external centralizers	29
RocLoc™ resin cartridges for resin fixed rock-bolts	30
ELEBAR™-G resin rock bolt installation tooling	31
ELEBAR™-G system accessories - Grout perfo socks	32
Grout pumps - Grouting plants	33
ELEBAR™-G system installation tooling - Nut torque wrenches	34
ELEBAR™-G pull-testing & stressing systems	35

Introduction

a versatile system that can solve any kind of rock reinforcement problem

Anchors, rock bolts, soil nails and micro-piles assembled with ELEBAR™-G threaded bars are considered as the advancement in rock reinforcement technology in comparison to older type systems using rebars or smooth bars.

Threaded bars are considered today as the Standard type in all developed countries with established high safety regulations (such as USA, Canada, European countries, South Africa etc.).

Depending on choices of accompanying accessories the ELEBAR™-G threaded bars can be used to form passive rock bolts (soil nails), point anchored rock bolts (resin or mechanical), combination bolts as well as temporary or permanent, passive or prestressed ground anchors or micro-piles.



ELEBAR™-G Thread-Bar features

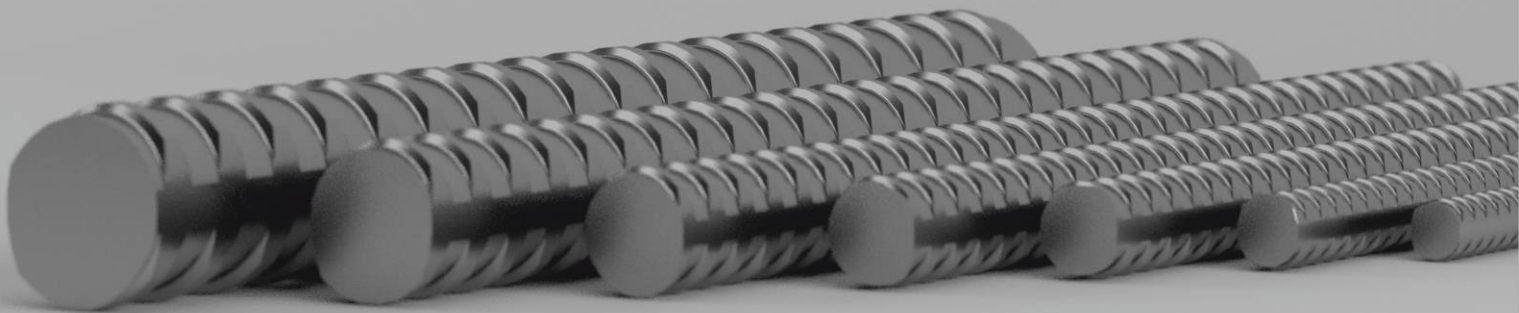

High tensile strength G-thread bar

The full-length continuous thread of the bar is formed by hot-rolling. The threads are shaped by local compressing and swelling of the steel without any removal of material, as opposed to cutting of threads in a turning lathe. The rolling process induces strain hardening to the steel, resulting mechanical strength increases compared to unprocessed raw material.

Application flexibility

The continuous thread enables cutting of the ELEBAR™-G bar at any point to form shorter bars. System couplers offer extensions to longer lengths. Thus, in the event of changes of reinforcement length requirements after bars have been supplied, purchased bars do not become useless, but it is easy and economical to adapt to those changes.

Retensioning ability

The continuous G-thread enables retensioning of the rock-bolt in the event of scaling (for example in case of slip when rock bolt is installed close to the blasting face). The continuity of the ELEBAR™-G thread offers unlimited retensioning in contrast to other types of bars having only a short thread formed at the bar end and become useless in the event of scaling.

Robust, non-sensitive thread

The robust continuous coarse G-thread is insensitive to harsh handling at the job site without affecting threadability.

Increased bond strength to grout

The continuity and the profile design of the G-thread offers enlarged contact surface and improved interlocking with the grout increasing the mechanical bonding strength to the surrounding grout.

Excellent resin mixing (for resin rock bolts)

The continuity and the profile design of the G-thread offers excellent mixing of the resin cartridge constituents while spinning stage for resin fixed rock bolt installations.

Corrosion protection

The design and large pitch of the continuous G-thread is ideal to receive hot-dip galvanizing and/or epoxy paint coats, whilst maintaining threadability of the ELEBAR™-G system.

Applications

Tunneling - Underground mining

- radial rock bolting,
- forepoling,
- tunnel entrance preparation/support,
- tunnel face stabilization,
- slope stabilization,
- tunnel arch fixing,
- arch/frame foundation piling.

Geotechnics - Civil engineering

- slope/embankment stabilization,
- soil nailing,
- injection piling,
- foundation strengthening,
- ground anchoring (temporary SCP or permanent DCP).

Energy projects

- fixing of photovoltaic solar cell panel frame bases,
- foundation of wind turbines, etc.



Applications



**wide range of applications
in geotechnical and civil engineering projects**

ELEBAR™ -G steel grades

Standard Grade (/S) - 500/550, 555/700 MPa

Thread type			G16	G20	G25	G28	G32	G40	G50	G57.5	G63.5	G75	
Thread direction			left hand										
Nominal diameter	D	mm	16	20	25	28	32	40	50	57,5	63,5	75	
Max diameter	D _{max}	mm	17,9	22,4	27,9	31,2	35,7	44,6	55,6	63,0	69,0	81,5	
Nominal cross-section	S	mm ²	201	314	491	616	804	1.257	1.963	2.597	3.167	4.418	
Nominal weight		kg/m	1,58	2,47	3,85	4,83	6,31	9,87	15,41	20,38	24,86	34,68	
Yield strength	f _{yk}	N/mm ²	500						550			500	
Tensile strength	f _{tk}	N/mm ²	550						700			550	
Elongation	A	%	> 6						> 5				
Typical yield load	F _{0,2k}	kN	100	157	246	308	402	629	982	1.441	1.758	2.209	
Minimum fracture load	F _{tk}	kN	110	172	270	339	442	691	1.078	1.818	2.217	2.430	
Colour codings	Size		N.C.	BLUE	RED	GREEN	WHITE	N.C.	ORANGE	GREY	YELLOW	N.C.	
	Grade		NO COLOR (N.C.)										

Standard Plus Grade (/P) - 550/620 MPa

Thread type			G20	G25	G28	G32	G40	G50	G57.5	G63.5	G75	
Thread direction			left hand									
Nominal diameter	D	mm	20	25	28	32	40	50	57,5	63,5	75	
Max diameter	D _{max}	mm	22,4	27,9	31,2	35,7	44,6	55,6	62,8	69,0	81,5	
Nominal cross-section	S	mm ²	314	491	616	804	1.257	1.963	2.597	3.167	4.418	
Nominal weight		kg/m	2,47	3,85	4,83	6,31	9,87	15,41	20,39	24,86	34,68	
Yield strength	f _{yk}	N/mm ²	550									
Tensile strength	f _{tk}	N/mm ²	620									
Elongation	A	%	> 5									
Typical yield load	F _{0,2k}	kN	173	270	339	442	691	1.080	1.428	1.742	2.430	
Minimum fracture load	F _{tk}	kN	195	304	382	499	779	1.217	1.610	1.963	2.739	
Colour codings	Size		BLUE	RED	GREEN	WHITE	N.C.	ORANGE	GREY	YELLOW	N.C.	
	Grade		BLUE									

N.C.: No colour

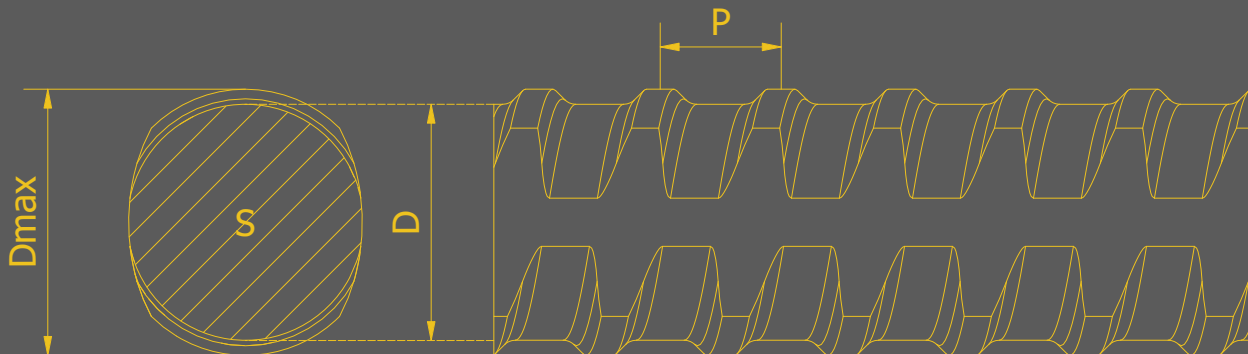

ELEBAR™ -G steel grades

Medium Grade (/M) - 670/800 MPa								
Thread type			G35	G43	G50	G57.5	G63.5	G75
Thread direction			right hand					
Nominal diameter	D	mm	35	43	50	57,5	63,5	75
Max diameter	D _{max}	mm	39,2	47,9	54,6	62,8	69,0	81,5
Nominal cross-section	S	mm ²	962	1.452	1.963	2.597	3.167	4.418
Nominal weight		kg/m	7,55	11,40	15,41	20,39	24,86	34,68
Yield strength	f _{yk}	N/mm ²	670					
Tensile strength	f _{tk}	N/mm ²	800					
Elongation	A	%	>5					
Typical yield load	F _{0.2k}	kN	645	973	1.315	1.740	2.122	2.960
Minimum fracture load	F _{tk}	kN	770	1.162	1.570	2.078	2.534	3.534
Colour codings	Size		BLUE	RED	ORANGE	GREY	YELLOW	N.C.
	Grade		GREEN					

High Grade (/T) - 900/1.100 MPa								
Thread type			G20	G25	G28	G32	G40	
Thread direction			left hand					
Nominal diameter	D	mm	20	25	28	32	40	
Max diameter	D _{max}	mm	22,4	27,9	31,2	35,7	44,6	
Nominal cross-section	S	mm ²	314	491	616	804	1.257	
Nominal weight		kg/m	2,47	3,85	4,83	6,31	9,87	
Yield strength	f _{yk}	N/mm ²	900					
Tensile strength	f _{tk}	N/mm ²	1.100					
Elongation	A	%	>5					
Typical yield load	F _{0.2k}	kN	280	440	550	720	1.130	
Minimum fracture load	F _{tk}	kN	340	540	670	880	1.380	
Colour codings	Size		BLUE	RED	GREEN	WHITE	N.C.	
	Grade		YELLOW					

N.C.: No colour

guide to coding system

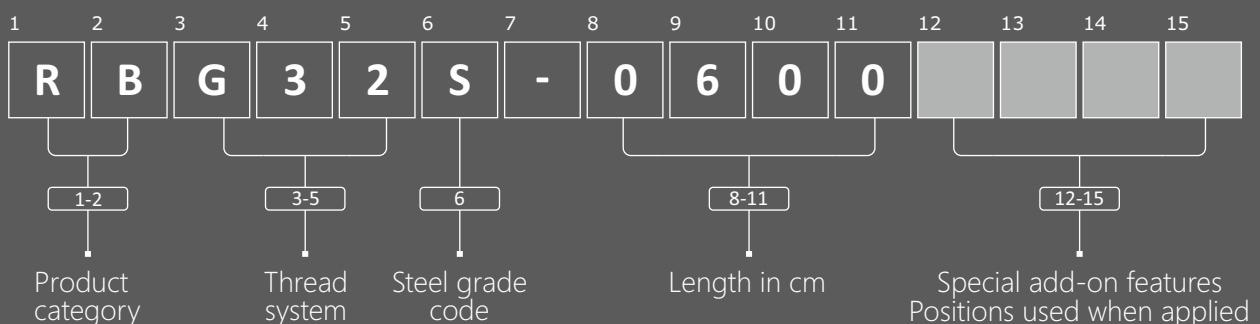

ELEBAR™-G cement grouted rock bolts (SN type anchors)

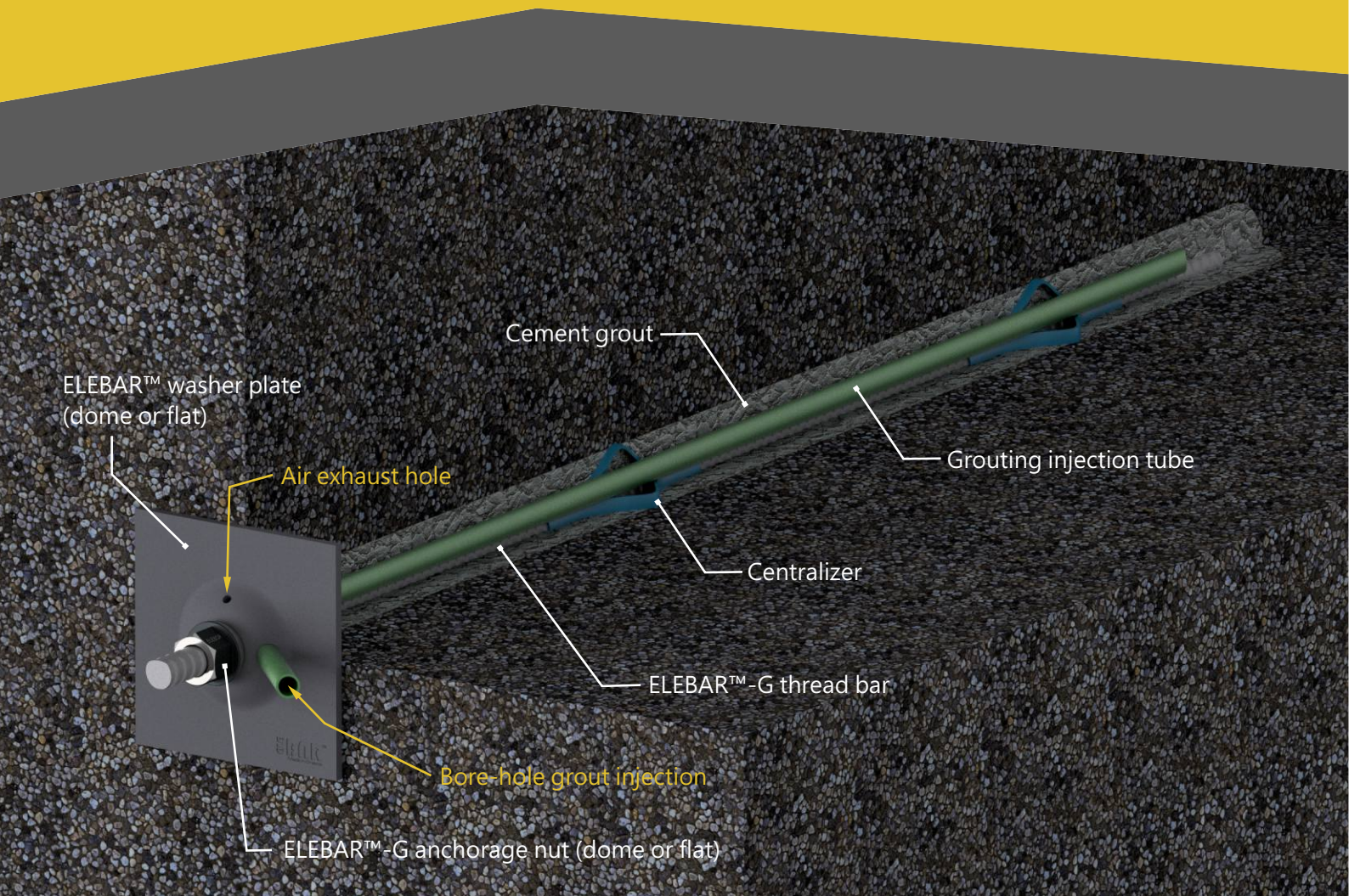

Cement fully grouted rock bolts are the most common type of passive rock bolts readily employed in tunnelling and many geotechnical applications. These type of rock bolts are commonly referred to as SN-anchors.

The use of ELEBAR™-G thread bars offers a series of advantages over conventional rebar type SN-anchors some of those being:

- External continuous G-design thread enhances mechanical interlocking with the grout offering very effective ground/rock improvement,
- Thread bars can be cut to size or extended with the aid of system couplers to any final length.

Main system components are :

- ELEBAR™-G thread bar
- ELEBAR™-G anchorage nut
- Domed or flat washer plate
- Suitable number of plastic bore-hole centralizers
- Bore-hole injection tube (optional, depending of mode of application).

The thread bar fitted with a suitable number of centralizers is force-inserted into a cement pre-filled bore-hole. This method is the most simple way to achieve a SN-anchor rock bolt, however results in considerable grout spillage.

To avoid this, a dedicated injection hose can be used to direct the grout to the bore-hole end. The grout gradually fills the bore-hole displacing the air which expels from a hole on the washer plate. Injection commences when grout is noted to exit the exhaust hole. This later method offers control over grout volumes as well as enables the installer to make grouting at any chosen time.

Various type of corrosion protection coatings can be applied onto the steel members of the rock bolts. These include Hot-Dip Galvanizing or Epoxy paints.

ELEBAR™-G mechanical anchors (expansion shell anchors)

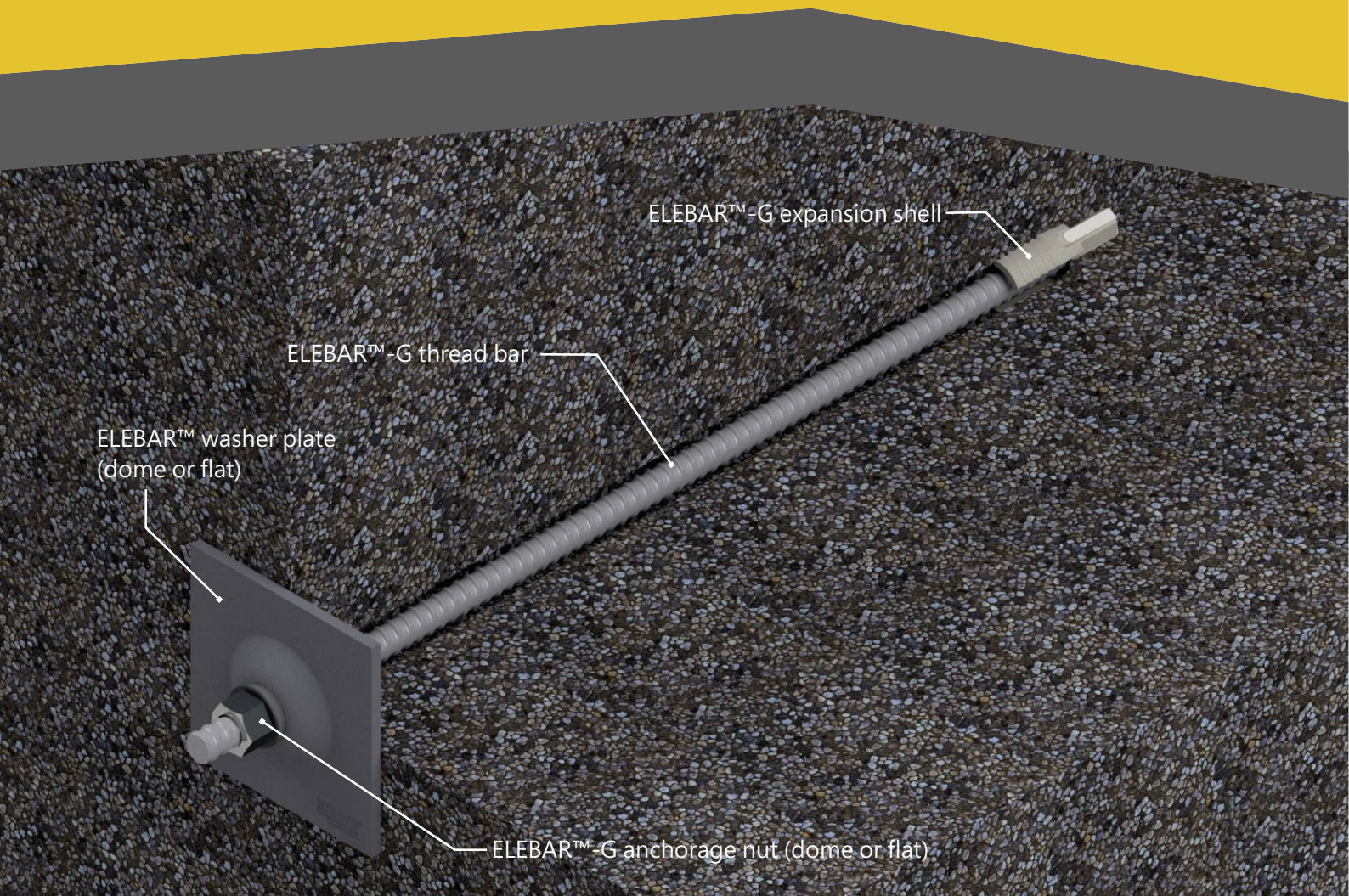

When an expansion shell is fitted at the tip of the ELEBAR™-G thread bar, transforms the rock bolt into a point anchored ground anchor.

The expansion shell is activated mechanically, thus these anchors are traditionally know as mechanical anchors. Upon expansion of the shell, system is pre-tensioned offering immediate rock support.

Main system components are :

- ELEBAR™-G thread bar
- ELEBAR™-G anchorage nut
- Domed or flat washer plate
- ELEBAR™-G bail type expansion shell.

The ELEBAR™-G bail type expansion shells incorporate two (2) or three (3) leafs ensuring an even load distribution at the anchor point. The leafs are held in position by means of a strap with a specially designed top cap that is intended to pop-out when subjected to excess loading.

During rock-bolt installation, the top cap of the strap remains in position providing initial resistance to the bolt thus enabling initial anchoring.

As tensioning of the bolt increases the top cap fails and pops out thus enabling the ELEBAR™-G bar to pass through the strap head. By this way complete tensioning of the rock-bolt is achieved and the bearing plate can securely rest against the rock face.

The serrations on the leafs are rounded-off to reduce point loading at the contact points of the shell with the rock. This feature also reduces crushing and breaching of the rock, thus taking advantage of the strength of the undisturbed rock at the anchor point.

ELEBAR™-G resin rock bolts/anchors

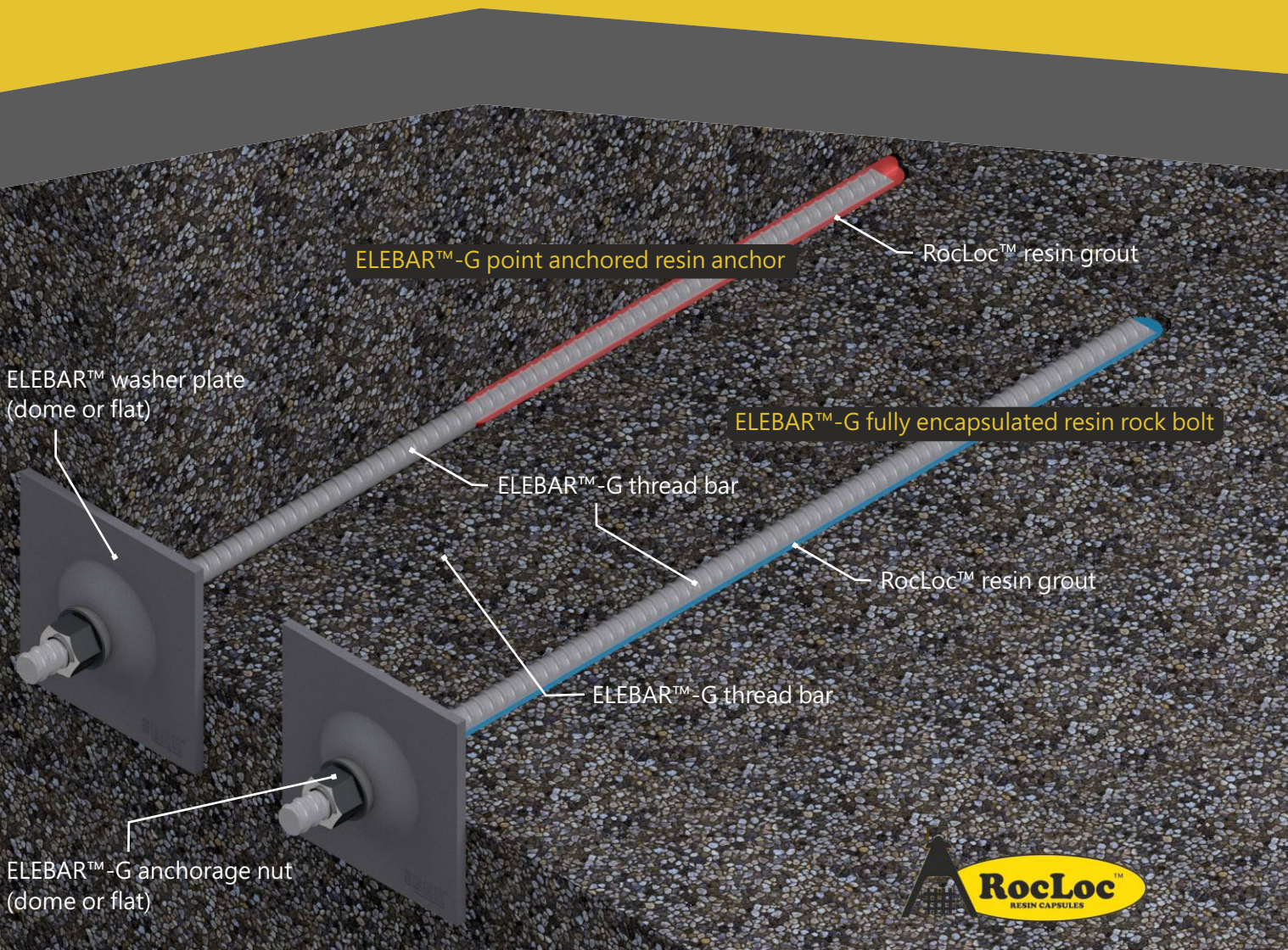

Resin fixed bolts are nowadays a common choice for rock support for many underground mines. The high installation speed with automation capability and the immediate rock support offered by this kind of rock-bolt installation method are the main factors for this choice.

The bore-hole is drilled to a depth few centimeters longer than the ELEBAR™-G thread bar. The resin cartridges are then manually or mechanically inserted in the drilled hole. The ELEBAR™-G thread bar is forced into the hole while simultaneously is being rotated. This step is known as the "spinning stage" which typically lasts only few seconds and serves the purpose of an effective mixing of the 2 capsule constituents, i.e. the resin with the hardener. To ease the cartridge membrane rupture the end of the thread bar is usually angle cut to 45° in order to form a sharp tip. After spinning ceases, the bar must be left immobile in order to allow the reaction to take place to full hardening of the resin. The duration of this stage depends on the resin grade choice and can be from few seconds to

several minutes. This time is frequently referred to as the holding time or setting time. Upon resin setting, the anchor nut can be tighten to designed torque and installation is then finished.

If resin fixes only a section of the bar a point anchored bolt is achieved, which can be torque tensioned to form an active pre-stressed anchor. If however, resin encapsulates the entire bar, then a passive rock-bolt is yielded.

Key advantages for using resin bolts despite the higher cost are:

- high load transmission due to high bonding strength,
- short setting times allow fast bearing support of the rock-bolt and overhead roof bolting
- ease and speed of installation,
- simple and safe handling,
- Full length encapsulation or point anchoring possible,
- suitable for automated installations due to possibility of pneumatic firing and use of automation installation tools.

ELEBAR™-G combination bolts (Combi-Bolts CBE/CBR)

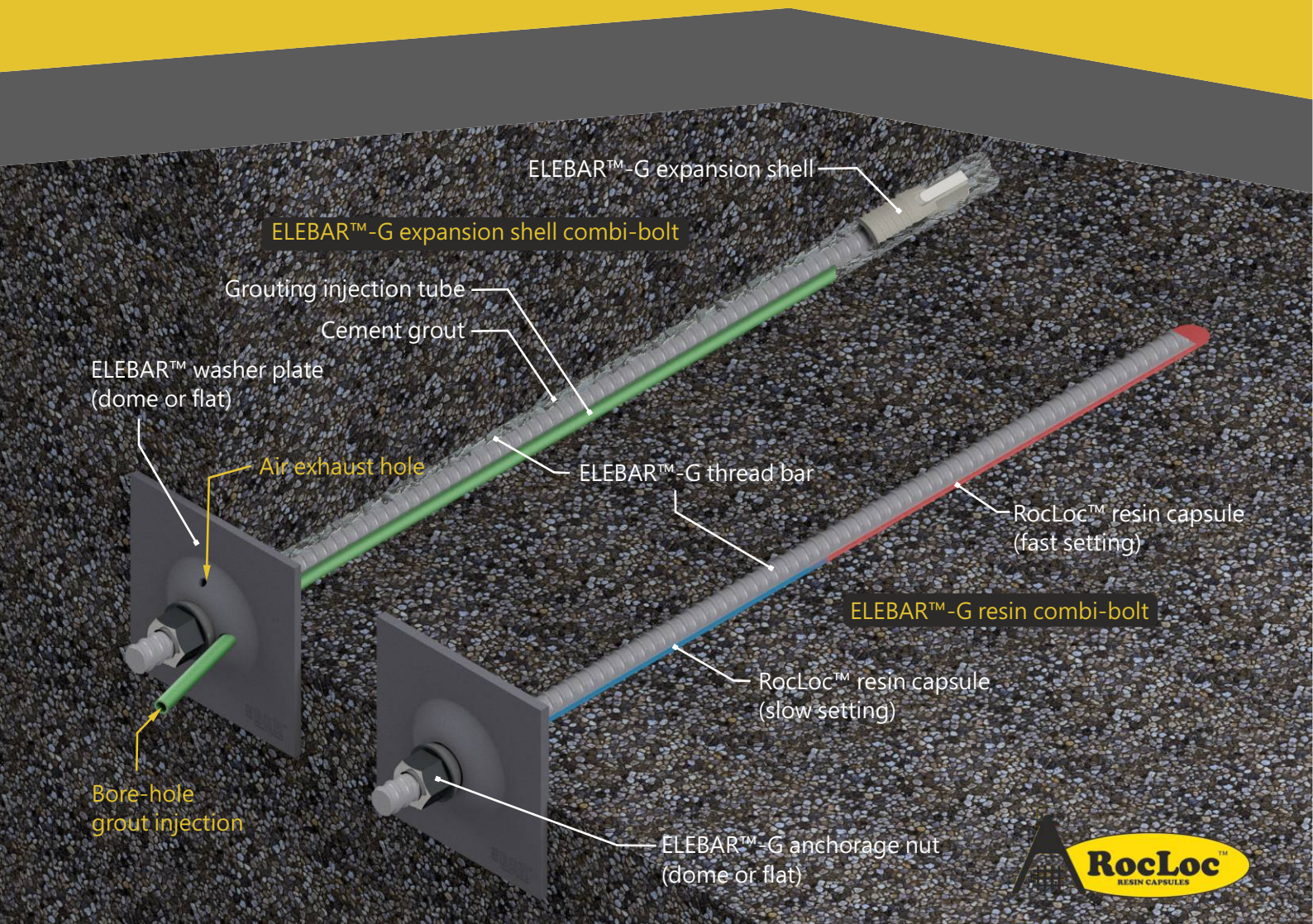

Combination bolts (CB) are all types of rock bolts that combine the benefits of point fixed anchors with the safety of fully encapsulated rock bolts.

There are several ways to achieve combination bolts with the use of ELEBAR™-G thread bars. All installations have similar stages regardless of the system differences. First stage is to achieve fixing of the end section of the thread bar to the rock, followed by anchorage nut torque tensioning. Finally, the entire bore-hole is encapsulated by cementitious or resinous grout.

Main system advantages of ELEBAR™-G combination bolts:

- immediate rock support upon nut torque tensioning,
- high levels of safety due to the system locking by the fully encapsulation,
- high levels of corrosion protection can be achieved.

ELEBAR™-G Expansion Shell Combi-Bolt (CBE)

The assembled rock bolt is inserted in the bore-hole with the washer plate being pushed against the rock. Nut is torque tensioned to expand the shell to achieve the point anchoring and the anchor pre-stressing. Subsequently cementitious or resinous grout is injected through the provided hose. The anchor shaft is totally encapsulated when grout expels from the anchorage plate exhaust hole.

ELEBAR™-G Resin Combi-Bolt (CBR)

Resin combination bolts are installed identically to the fully encapsulated resin rock-bolts. The only difference is that fast and slow setting resin cartridges are used in the same hole. Fast reaction cartridges are inserted first in the bore-hole followed by a suitable number of slow setting ones. Spinning and holding times of the fast setting resin are respected. Nut torque tensioning pre-stresses the anchor. Subsequent hardening of the slow setting resin transforms the system to a combination bolt.

ELEBAR™-G temporary soil nails (SCP - single/standard corrosion protection)

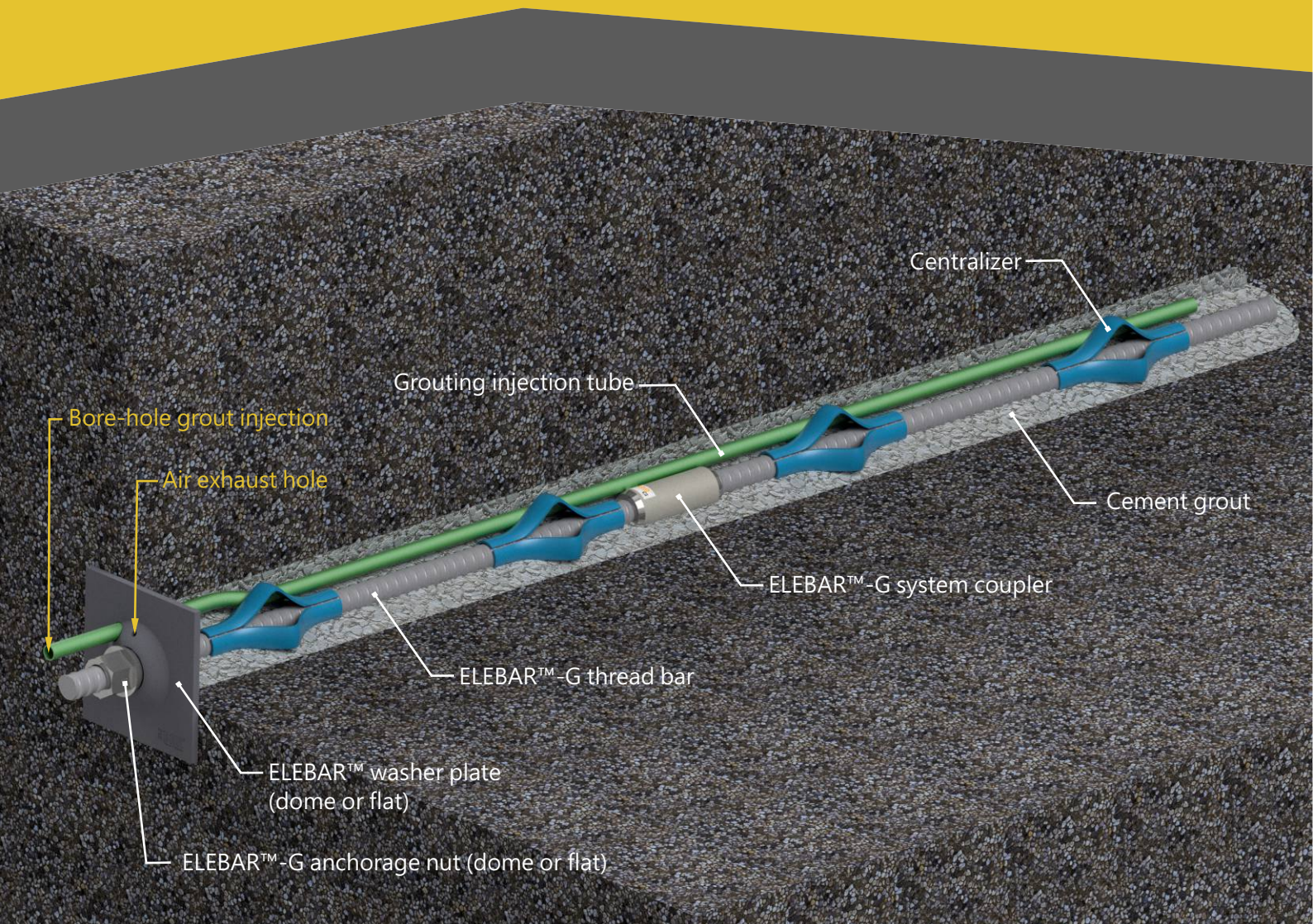

ELEBAR™-G thread bar soil nails is a passive reinforcing system commonly chosen to stabilize slopes, embankments, retaining walls and deep excavations. The soil nailing method aims to apply reinforcing effects via the ELEBAR™-G thread bar across potential slip planes within the soil mass.

Load bearing takes place by tensile and shear forces acting on the nails by friction transfer from the rock to the thread bar reinforced grouted column.

Fields of applications include :

- slope stabilization,
- stabilization of embankment,
- rock stabilization,
- excavation pits stabilization,
- rock fall barrier and mesh fixation.

For temporary applications, the ELEBAR™-G thread bar soil nails are installed in respect with the guidelines of Single Corrosion Protection (SCP) reinforcing systems as described in the European Standard EN 1537:2013.

Soils nails typically require larger diameter bore-holes than those used for fully encapsulated rock-bolts. The ELEBAR™-G thread bar assembled with centralizers and a grouting tube is inserted in a suitable size bore-hole. Grouting takes place and upon grout hardening the anchorage is fitted. Light nut torque tensioning can induce some small stress forces behind the anchorage. The anchorage can be fitted also immediately upon insertion of the nail body into the bore-hole. This modification, offers the option to perform the grouting at any time convenient to the job-site working steps plan. This option requires the anchorage plate to feature 2 extra holes, one for the grouting tube and one for air exhaustion.

ELEBAR™-G permanent soils nails (DCP - double corrosion protection)

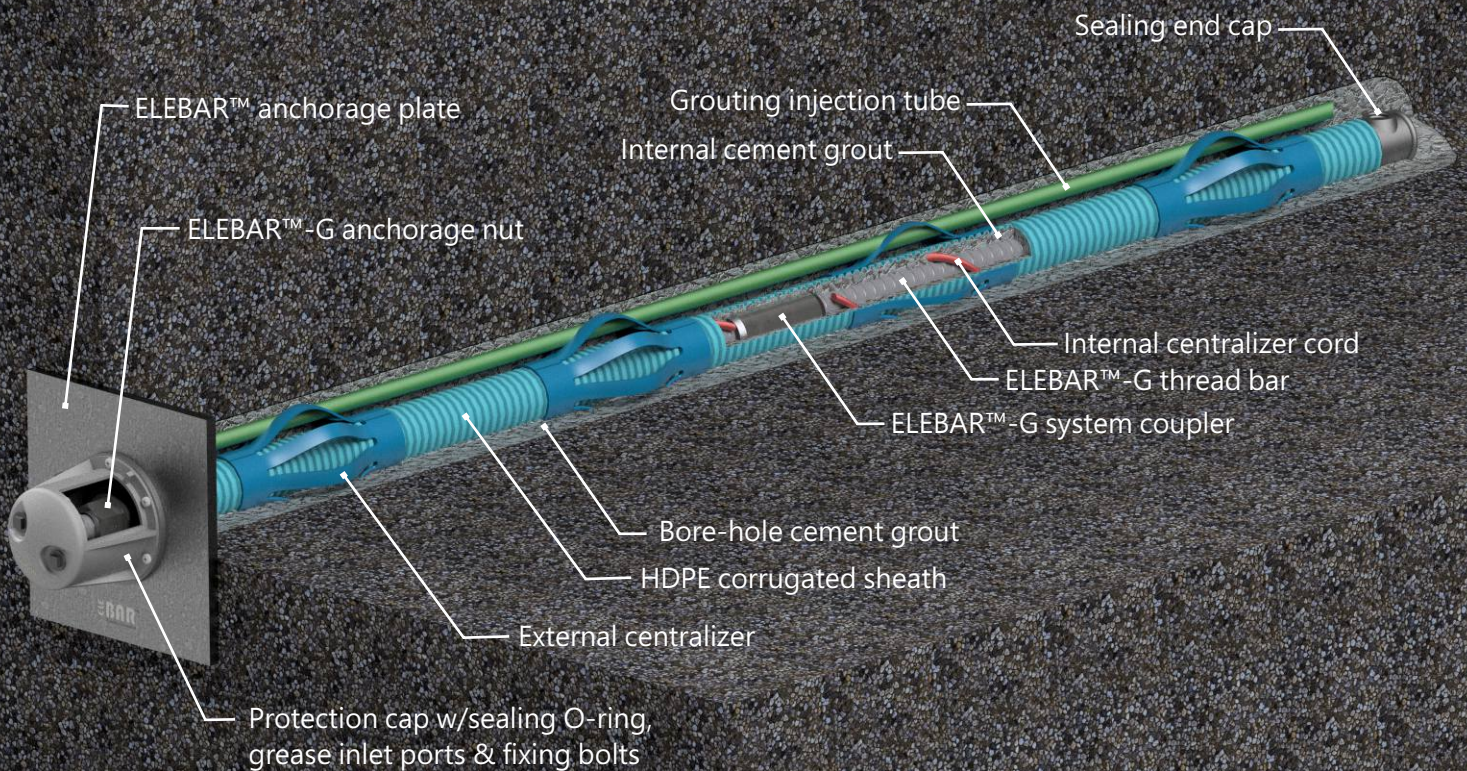

ELEBAR™-G thread bar soil nails is a passive reinforcing system commonly chosen to stabilize slopes, embankments, retaining walls and deep excavations. The soil nailing method aims to apply reinforcing effects via the ELEBAR™-G thread bar across potential slip planes within the soil mass.

Load bearing takes place by tensile and shear forces acting on the nails by friction transfer from the rock to the thread bar reinforced grouted column.

Fields of applications include :

- slope stabilization,
- stabilization of embankment,
- rock stabilization,
- excavation pits stabilization,
- rock fall barrier and mesh fixation.

For permanent applications, the ELEBAR™-G thread bar soil nails are installed in respect with the guidelines of Double Corrosion Protection (DCP) reinforcing systems as described in the European Standard EN 1537:2013. This requires the entire ELEBAR™-G thread bar soil nail to be encapsulated in plastic sheathing, including as well the protection of the anchorage.

DCP soils nails typically require larger diameter bore-holes than those used for same size SCP versions, as extra space is necessary to house the corrugated sheathing. The system requires grouting of both the internal part of the corrugated sheath as well as the external for achieving the bore-hole filling and bonding to the rock.

A series of plastic components are necessary for achieving the Double Corrosion Protection soil nail concept as illustrated in the above picture.

ELEBAR™-G temporary ground anchors (SCP - single/standard corrosion protection)

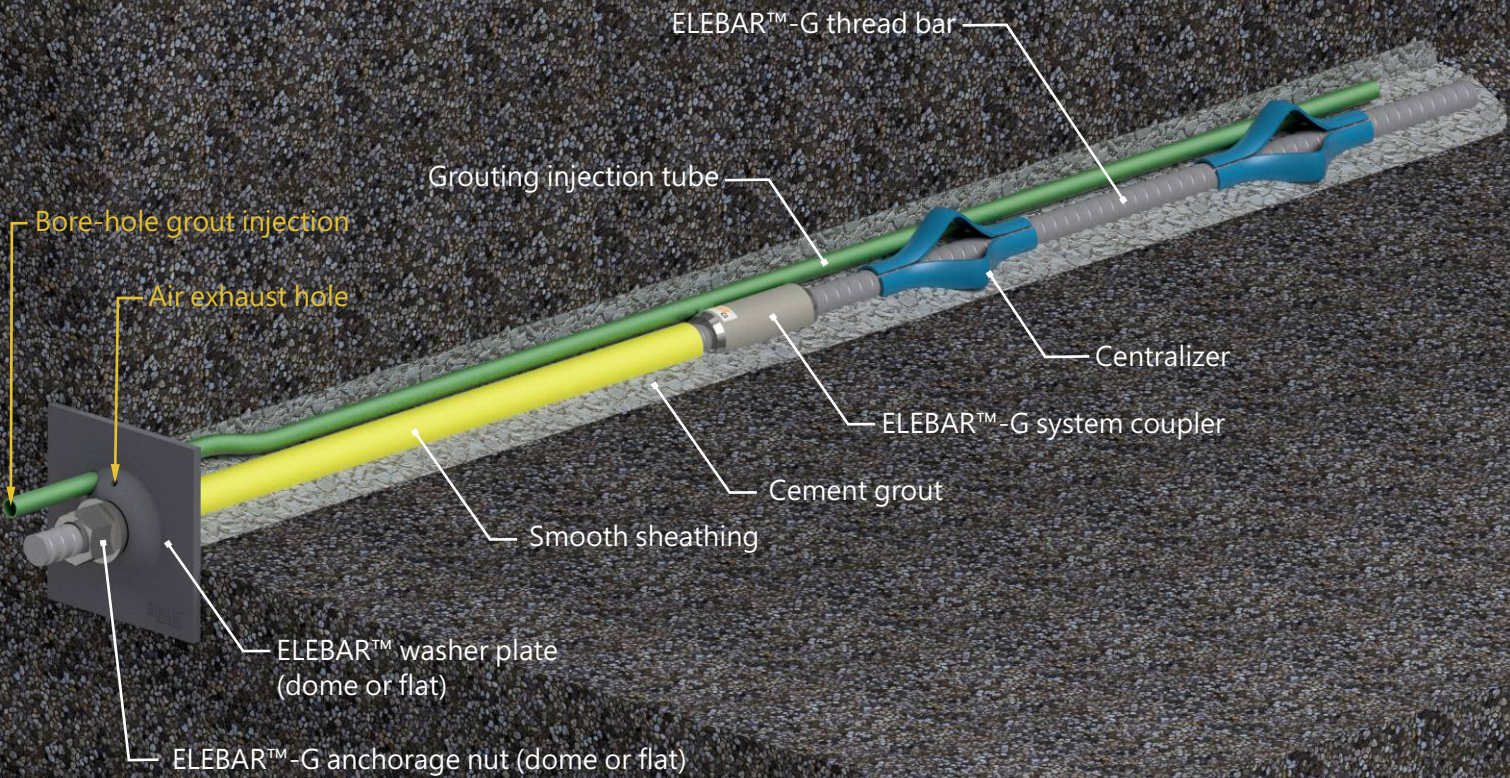

ELEBAR™-G thread bar ground anchor is an active system imposing movement restraints to structures by applying compressive loads. ELEBAR™-G ground anchors are in fact post-tensioned thread-bars.

In order to successfully achieve post-tensioning, the bonded length of the system must be anchored inside coherent rock. This frequently requires very long anchors to be assembled, which is an ideal use for the ELEBAR™-G thread bars as the system is extendable to any final length by the full load capacity bearing couplers.

The unbonded section of the system also frequently referred to as the "free-length" receives the stressing by hydraulic jack pull elongation. Once the designed load has been applied, the anchor is locked-off by nut threading at the anchorage head. Upon locking, the anchor applies a compressive load to the structure restricting movement.

One of the biggest advantages of ground anchors is that they reduce the space required compared to other traditional construction methods, thus enable constructions in densely populated areas otherwise impossible.

Fields of applications include :

- rock and slope stabilization,
- stabilization of embankment,
- dam construction,
- excavation pits,
- uplift restraining,
- tiebacks.

For temporary applications, the ELEBAR™-G thread bars are installed in respect with the guidelines of Single Corrosion Protection (SCP) ground anchors as described in the European Standard EN 1537:2013.

ELEBAR™-G permanent ground anchors (DCP - double corrosion protection)

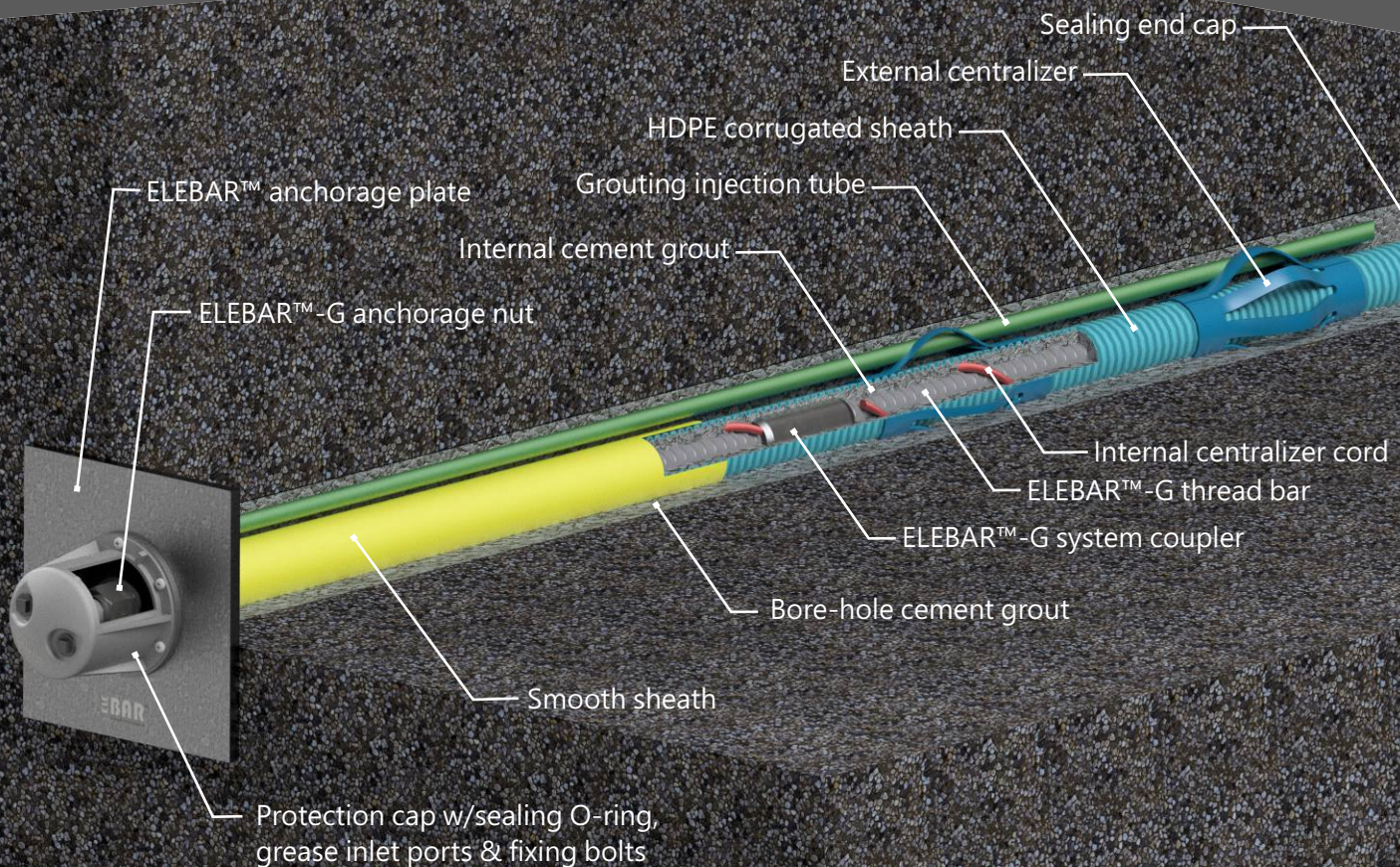

ELEBAR™-G thread bar ground anchor is an active system imposing movement restraints to structures by applying compressive loads. ELEBAR™-G ground anchors are in fact post-tensioned thread-bars.

In order to successfully achieve post-tensioning, the bonded length of the system must be anchored inside coherent rock. This frequently requires very long anchors to be assembled, which is an ideal use for the ELEBAR™-G thread bars as the system is extendable to any final length by the full load capacity bearing couplers.

The unbonded section of the system also frequently referred to as the "free-length" receives the stressing by hydraulic jack pull elongation. Once the designed load has been applied, the anchor is locked-off by nut threading at the anchorage head. Upon locking, the anchor applies a compressive load to the structure restricting movement.

One of the biggest advantages of ground anchors is that they reduce the space required compared to other traditional construction methods, thus enable constructions in densely populated areas otherwise impossible.

Fields of applications include :

- rock and slope stabilization,
- stabilization of embankment,
- dam construction,
- excavation pits,
- uplift restraining,
- tiebacks.

For permanent applications, the ELEBAR™-G thread bars are installed in respect with the guidelines of Double Corrosion Protection (DCP) ground anchors as described in the European Standard EN 1537:2013.

ELEBAR™-G temporary micropiles (SCP - single/standard corrosion protection)

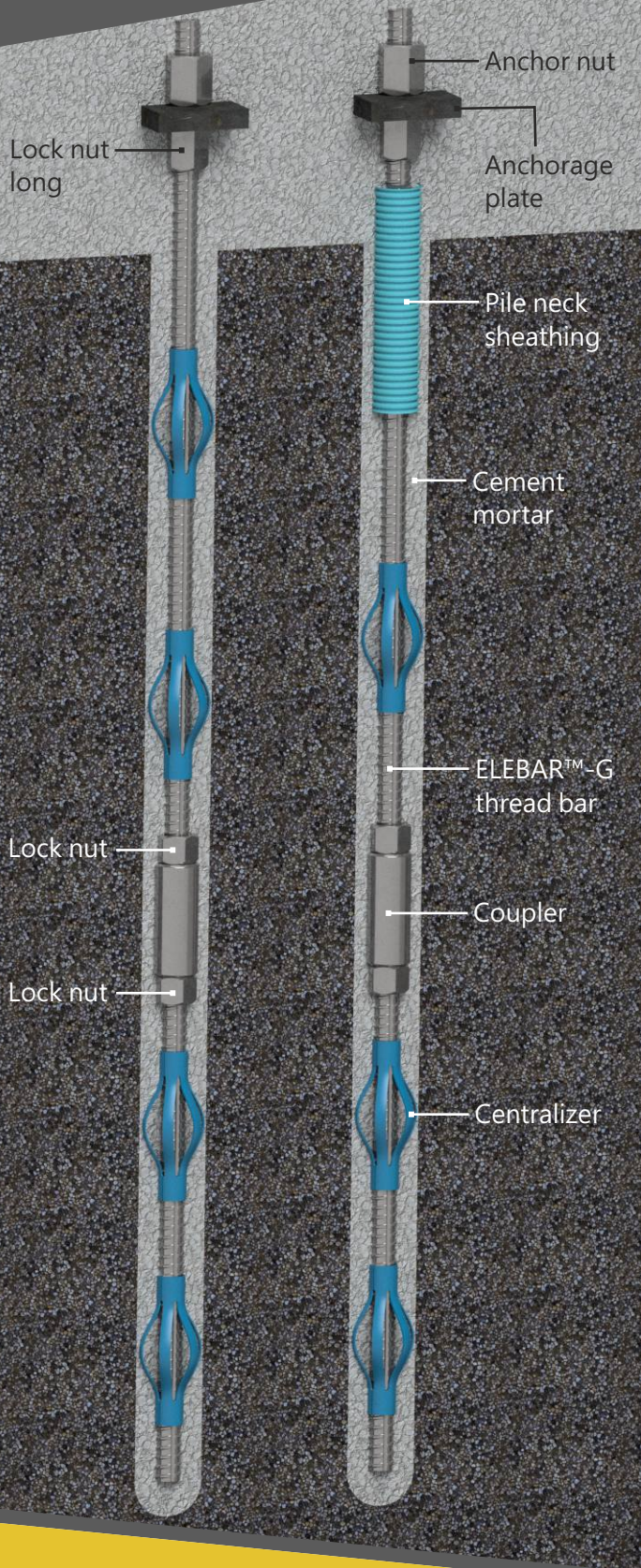

A nowadays frequent employment of ELEBAR™-G thread bars is as reinforcing elements of micropiles. These are foundation elements as traditional piles but are of smaller diameters typically not exceeding 300mm. The high ratio of strength to cross-sectional area of ELEBAR™-G thread bars make them ideal choice for forming piles with small diameters, thus why named "micropiles".

Micropiles are typically installed with same principles as the fully encapsulated soil nails and act as passive foundation systems. Main difference is that the pile head (anchorage) is left exposed above the rock/soil substrate and is subsequently casted in the concrete foundation superstructure.

The function of micropiles is to transfer loads through interface friction forces into deeper, stable soil/rock strata. The body of the micropile is inserted into a suitable size bore-hole and is subsequently grouted with cement mortar from the bottom upwards. The grout has a dual function. It is the intermediate element for load transfers to take place but also due to its alkalinity provides a protection of the steel members against corrosion.

If the function of the micropile is designed as temporary, the micropile is installed with same principles as the Single Corrosion Protected (SCP) soil nails with respect to the general guidelines of the the European Standard EN 1537:2013. Temporary micropiles should have at least a 15mm cement cover around the thread bar. For extended life expeçantancies coatings like Zn galvanization may be utilized as well as design calculations considering sacrificial corrosion rates. If the quality of seal at the pile head connection area is uncertain, a corrugated sheathing tube is frequently installed at the pile neck.

Fields of applications include :

- foundations,
- buoyancy of base plates,
- underpinnings,
- excavation pits,
- uplift restraining,
- dam constructions.

ELEBAR™-G permanent micropiles (DCP - double corrosion protection)

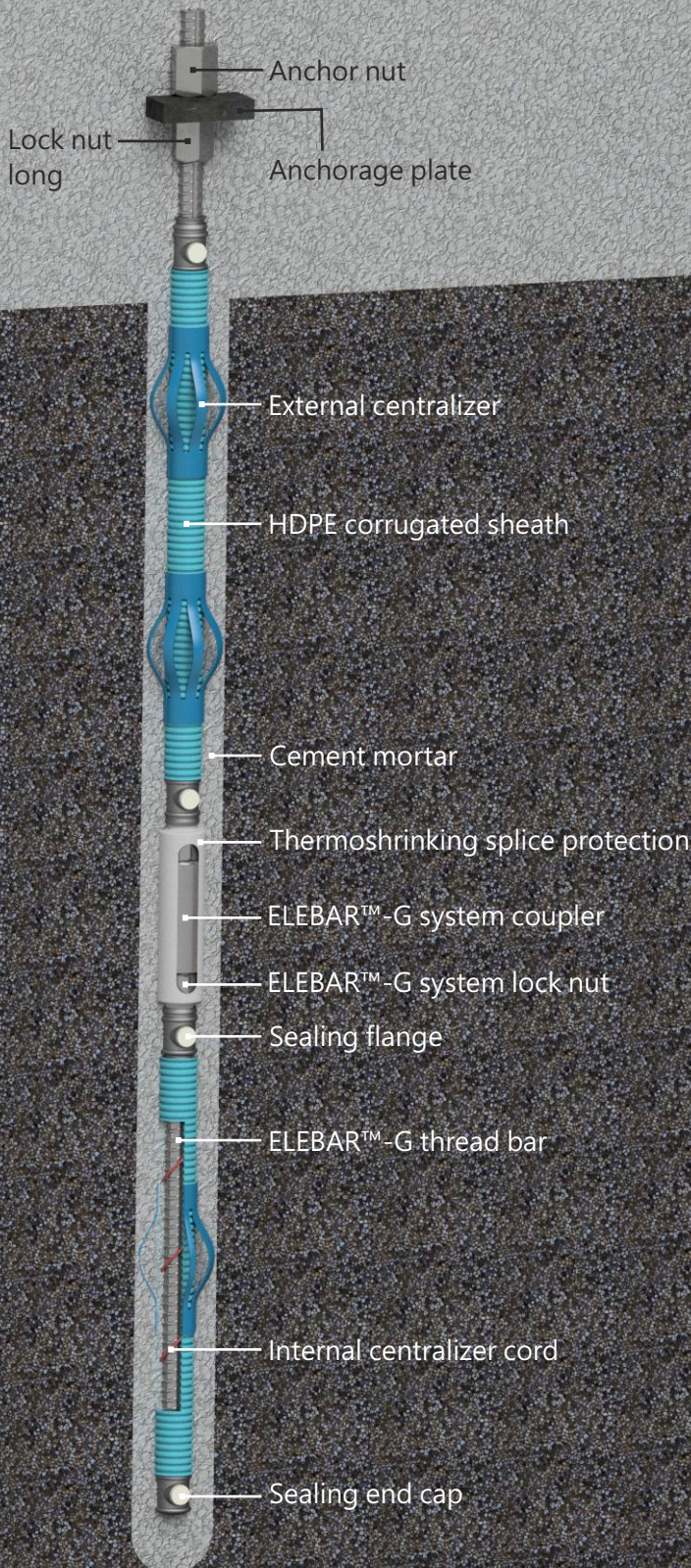

A nowadays frequent employment of ELEBAR™-G thread bars is as reinforcing elements of micropiles. These are foundation elements as traditional piles but are of smaller diameters typically not exceeding 300mm. The high ratio of strength to cross-sectional area of ELEBAR™-G thread bars make them ideal choice for forming piles with small diameters, thus why named "micropiles" .

Micropiles are typically installed with same principles as the fully encapsulated soil nails and act as passive foundation systems. Main difference is that the pile head (anchorage) is left exposed above the rock/soil substrate and is subsequently casted in the concrete foundation superstructure.

The function of micropiles is to transfer loads through interface friction forces into deeper, stable soil/rock strata.

The body of the micropile is inserted into a suitable size bore-hole and is subsequently grouted with cement mortar from the bottom upwards. The grout has a dual function. It is the intermediate element for load transfers to take place but also due to it' s alkalinity provides a protection of the steel members against corrosion.

If the function of the micropile is designed as permanent the micropile is installed with same principles as the Double Corrosion Protected (DCP) soil nails with respect to the general guidelines of the the European Standard EN 1537:2013. DCP micropile body has to be encapsulated in plastic corrugated sheathing with a wall-thickness of at least 1mm and should have at least a 5mm cement cover around the thread bar.

Fields of applications include :

- foundations,
- buoyancy of base plates,
- underpinnings,
- excavation pits,
- uplift restraining,
- dam constructions.

ELEBAR™-G system components

Hexagonal nuts

Domed spherical nuts design code : 2044

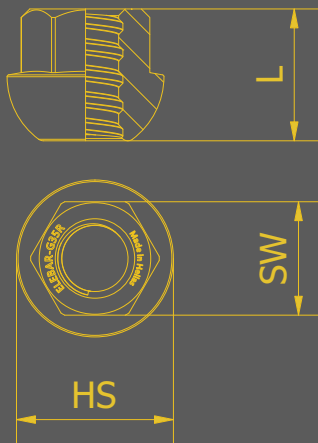

System	Part Nr.	SW mm	L mm	HS mm	Weight kg
G16 L	RBG16L-SDN27L35	27	33	35	0,10
G20 L	RBG20L-SDN36L45	36	45	50	0,32
G25 L	RBG25L-SDN41L45	41	45	55	0,37
G28 L	RBG28L-SDN46L55	46	55	60	0,55
G32 L	RBG32L-SDN50L65	50	60	65	0,65
G40 L	RBG40L-SDN60L70	60	70	88	1,30
G50 L	RBG50L-SDN80L85	80	85	107	2,60
G57.5 L	RBG57L-SDN90L10	90	100	120	4,15
G63.5 L	RBG63L-SDN10L11	100	115	144	6,00
G75 L	RBG75L-SDN12L12	120	120	165	9,69
G35 R	RBG35R-SDN60L70	60	70	83	1,30
G43 R	RBG43R-SDN70L85	70	85	102	2,20
G50 R	RBG50R-SDN80L10	80	100	116	3,59
G57.5 R	RBG57R-SDN90L11	90	115	137	5,50
G63.5 R	RBG63R-SDN10L12	100	125	151	7,30
G75 R	RBG75R-SDN12L15	120	150	174	11,90

Hexagonal load nuts design code : 2002

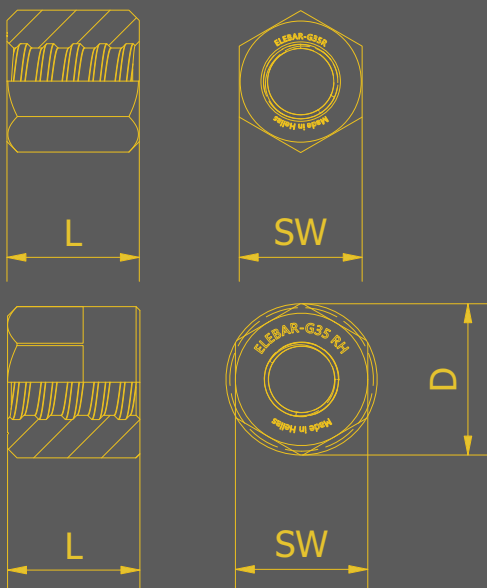

System	Part Nr.	SW mm	L mm	D mm	Weight kg
G16 L	RBG16L-HN3240	32	40	-	0,20
G20 L	RBG20L-HN3645	36	45	-	0,26
G25 L	RBG25L-HN4150	41	50	-	0,34
G28 L	RBG28L-HN4655	46	55	-	0,48
G32 L	RBG32L-HN5560	55	60	-	0,78
G40 L	RBG40L-HN6570	65	70	-	1,18
G50 L	RBG50L-HN8085	80	85	-	2,17
G57.5 L	RBG57L-HN9010	90	100	102	3,65
G63.5 L	RBG63L-HN1013	100	135	114	6,57
G75 L	RBG75L-HN1010	100	100	108	2,90
G35 R	RBG35R-HN6570	65	70	-	1,37
G43 R	RBG43R-HN8090	80	90	-	2,62
G50 R	RBG50R-HN8010	80	100	-	2,80
G57.5 R	RBG57R-HN9012	90	120	102	4,42
G63.5 R	RBG63R-HN1011	100	110	110	4,70
G75 R	RBG75R-HN1013	100	130	108	4,90

ELEBAR™-G system components

Hexagonal nuts

System	Part Nr.	SW mm	L mm	D mm	Weight kg
G16 L	RBG16L-HN3230	32	30	-	0,15
G20 L	RBG20L-HN3240	32	40	-	0,16
G25 L	RBG25L-HN4140	41	40	-	0,25
G28 L	RBG28L-HN4145	41	45	-	0,26
G32 L	RBG32L-HN5050	50	50	-	0,47
G40 L	RBG40L-HN6065	60	65	-	0,85
G50 L	RBG50L-HN8080	80	80	-	2,04
G57.5 L	RBG57L-HN9080	90	80	102	2,77
G63.5 L	RBG63L-HN9011	90	115	102	3,74
G75 L	RBG75L-HN1080	100	80	108	2,37
G35 R	RBG35R-HN5565	55	65	-	0,77
G43 R	RBG43R-HN7080	70	80	-	1,21
G50 R	RBG50R-HN8090	80	90	-	2,38
G57.5 R	RBG57R-HN9010	90	100	102	3,42
G63.5 R	RBG63R-HN1011	100	115	108	4,90
G75 R	RBG75R-HN1012	100	120	108	3,59

Lock nut, Long

design code : 2003

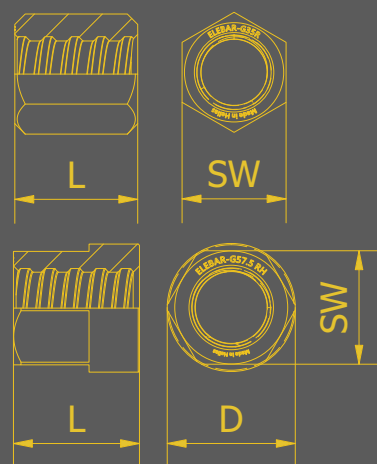

System	Part Nr.	SW mm	L mm	D mm	Weight kg
G16 L	RBG16L-HN3220	32	20	-	0,10
G20 L	RBG20L-HN3220	32	20	-	0,08
G25 L	RBG25L-HN4120	41	20	-	0,14
G28 L	RBG28L-HN4125	41	25	-	0,15
G32 L	RBG32L-HN5030	50	30	-	0,28
G40 L	RBG40L-HN6035	60	35	-	0,45
G50 L	RBG50L-HN8050	80	50	-	1,21
G57.5 L	RBG57L-HN9060	90	60	102	2,16
G63.5 L	RBG63L-HN9075	90	75	102	2,18
G75 L	RBG75L-HN1080	100	80	108	2,35
G35 R	RBG35R-HN5540	55	40	-	0,47
G43 R	RBG43R-HN7050	70	50	-	1,00
G50 R	RBG50R-HN8050	80	50	-	1,39
G57.5 R	RBG57R-HN9060	90	60	102	1,93
G63.5 R	RBG63R-HN1070	100	70	108	2,90
G75 R	RBG75R-HN1080	100	80	108	2,33

Lock nut, Short

design code : 2040

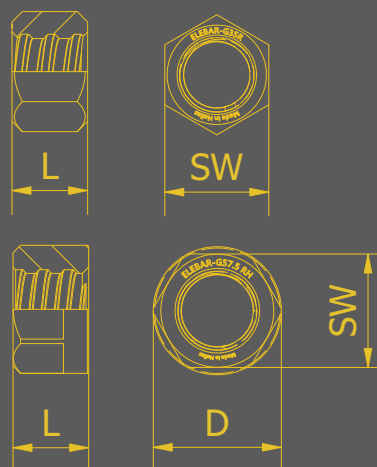

ELEBAR™-G system components

Couplers

Coupler, standard design code : 3003

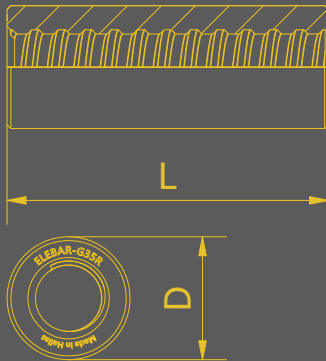

System	Part Nr.	D mm	L mm	Weight kg
G16 L	RBG16L-CS32090	32	90	0,70
G20 L	RBG20L-CS36105	36	105	0,52
G25 L	RBG25L-CS40115	40	115	0,61
G28 L	RBG28L-CS45125	45	125	0,85
G32 L	RBG32L-CS52140	52	140	1,26
G40 L	RBG40L-CS65160	65	160	2,34
G50 L	RBG50L-CS80200	80	200	4,23
G57.5 L	RBG57L-CS10230	102	230	10,31
G63.5 L	RBG63L-CS10260	102	260	9,55
G75 L	RBG75L-CS11240	108	240	8,07
G35 R	RBG35R-CS65170	65	170	2,95
G43 R	RBG43R-CS80200	80	200	5,42
G50 R	RBG50R-CS90210	90	210	7,24
G57.5 R	RBG57R-CS10250	102	250	10,31
G63.5 R	RBG63R-CS11300	114	300	14,48
G75 R	RBG75R-CS11260	108	260	8,74

Coupler with Centre Stop design code : 3002

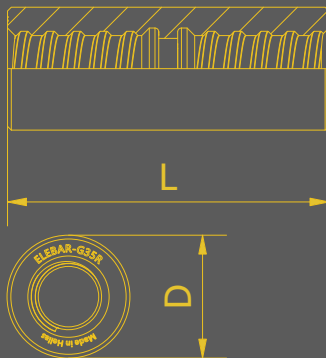

System	Part Nr.	D mm	L mm	Weight kg
G16 L	RBG16L-CS32090S	32	90	0,70
G20 L	RBG20L-CS36105S	36	105	0,52
G25 L	RBG25L-CS40115S	40	115	0,61
G28 L	RBG28L-CS45125S	45	125	0,85
G32 L	RBG32L-CS52140S	52	140	1,26
G40 L	RBG40L-CS65160S	65	160	2,34
G50 L	RBG50L-CS80200S	80	200	4,23
G57.5 L	RBG57L-CS10230S	102	230	10,31
G63.5 L	RBG63L-CS10260S	102	260	9,55
G75 L	RBG75L-CS11240S	108	240	8,07
G35 R	RBG35R-CS65170S	65	170	2,95
G43 R	RBG43R-CS80200S	80	200	5,42
G50 R	RBG50R-CS90210S	90	210	7,24
G57.5 R	RBG57R-CS10250S	102	250	10,31
G63.5 R	RBG63R-CS11300S	114	300	14,48
G75 R	RBG75R-CS11260S	108	260	8,74

ELEBAR™-G system components

Ring nuts & Expansion shells

System	Part Nr.	D mm	L mm	Weight kg
G20 L	RBG20L-RN85100	36	105	0,52
G25 L	RBG25L-RN41125	40	115	0,61
G28 L	RBG28L-RN46140	45	125	0,85
G32 L	RBG32L-RN50125	52	140	1,26

Ring nut.

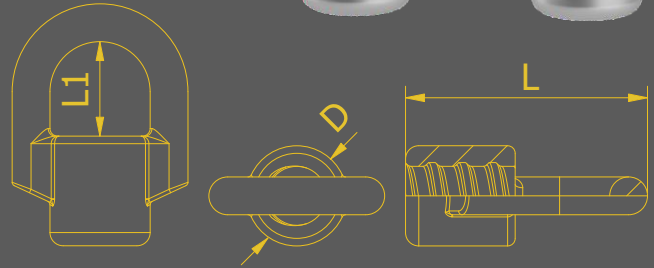

The ELEBAR™-G bail type expansion shells incorporate two (2) or three (3) leaves ensuring a more even load distribution at the anchor point.

The leaves are held in position by means of a strap with a specially designed top cap that is intended to pop-out when subjected to excess loading. During rock-bolt installation, the top cap of the strap remains in position providing initial resistance to the bolt thus enabling initial anchoring. As tensioning of the bolt increases the top cap fails and pops out thus enabling the ELEBAR™-G bar to pass through the strap head. By this way complete tensioning of the rock-bolt is achieved and the bearing plate can securely rest against the rock face.

The serrations on the leaves are rounded off to reduce point loading at the contact points of the shell with the rock. This feature also reduces crushing and breaching of the rock, thus taking advantage of the strength of the undisturbed rock at the anchor point.

Expansion shell

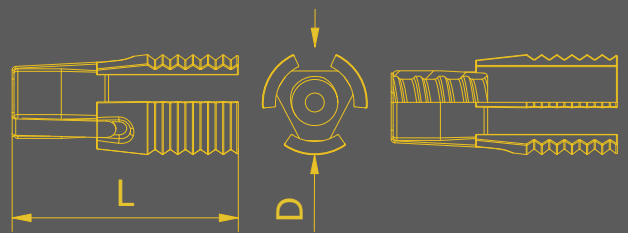

Type	G16L	G20L	G25L	G28L	G32L	Suggested bore-hole diameter (mm)																	
						30	32	34	36	38	40	42	44	46	48	50	52	54	56	58	60	62	64
BL 332	✓	✓ *	✗	✗	✗																		
BL 335	✓ *	✓	✓ *	✗	✗																		
BL 338	✗	✓	✓ *	✗	✗																		
BL 343	✗	✓	✓	✗	✗																		
BL 249	✗	✗	✓ *	✓	✗																		
BL 260	✗	✗	✗	✓ *	✓																		

- ✓ Produced items
- * Items available only on special request
- ✗ Non available items

ELEBAR™-G system accessories

Anchorage components

Washer plates

Bearing plates are available in flat or domed forms, in square, round or diamond shape geometries. The centre hole can be machine chamfered to house dome nuts. Depending on choices, it is possible to achieve articulation up to 15 degrees in all directions.

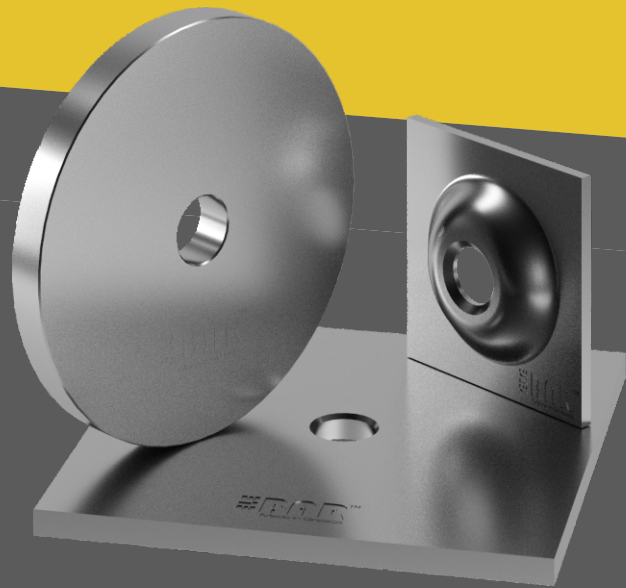

Angle compensation constructions

Angle compensation constructions can be made to customer or to project designer requirements.

Bearing plates can be incorporated into the design.



Anchorage protection systems

KP cap systems

Anchorage protection systems are necessary for permanent DCP systems in respect to the guidelines of the the European Standard EN 1537:2013. The KP type cap system is bolted onto the bearing plate.

The system features a UV resistant cap with 3 threaded plugs that provide access to the internal compartment in case greasing operations are to be carried out without being necessary to remove the entire cap assembly.

A large gasket provides hermetical sealing ensuring a high quality protection level. Caps in short and long height versions are available to ensure fitment up to 280mm bar protrusions.



ELEBAR™-G system components

Corrugated anchor sheathing

Encapsulation of the body of anchors and soil nails in plastic corrugated sheathing is a major feature for permanent double corrosion systems in respect to the guidelines of the the European Standard EN 1537:2013.

Corrugation shape of the sheathing is an important feature which enhances the mechanical interlocking between the internal grouted section with the outer sleeve thus maximizes the necessary load transfers which are of vital importance for the designed operation of the reinforcement system.

DUROTENE®, High Density Polyethylene (HDPE) corrugated sheaths are available in various wall thicknesses and diameters to match all sizes of ELEBAR™-G thread bar systems. Selected models feature a special modified profile at 1050mm intervals. When these systems are cut at these positions a male and female threaded end is formed at the opposed mating cut sections. This feature makes those systems connectable without the need to use separate connection sockets.

For all sizes various accessories are available such as:

- cone end caps with or without threading,
- perforated caps, with or without threading,
- wrapped type external centralizers,
- grout inlet flexible support that enables internal grouting operations,
- rubber flange and fittings with grout inlet ports.

DUROTENE® corrugated sheaths

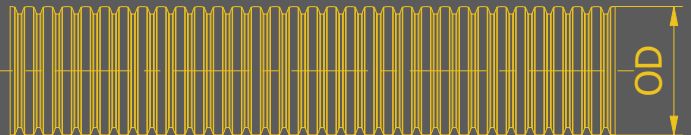
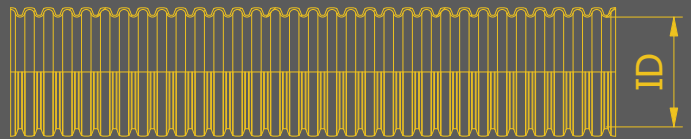

Size	OD mm	ID mm	Thickenss mm	Packaging
22 / 28	28	22	1,2	roll
45 / 55	55	45	1,2 ^[MF] /1,5	roll
49 / 57	57	49	1,5	roll
55 / 65	65	55	1,2 ^[MF]	roll
58 / 70	70	58	1,2 ^[MF] /1,5	roll
71 / 85	85	71	1,2 ^[MF] /1,5	roll
86 / 100	100	86	1,2 ^[MF] /1,5/2,0	roll
98 / 114	114	98	2,0	roll
100 / 114	114	100	1,2 ^[MF] /1,5	roll
105 / 117	117	105	1,2 ^[MF] /1,5	roll

[MF] : Model flush self-coupled (Male/Female)

DUROTENE® is registered name of SIREG Geotech SpA

ELEBAR™-G system components

Thermoshrinking smooth sheathing

High shrinkage THS sheaths

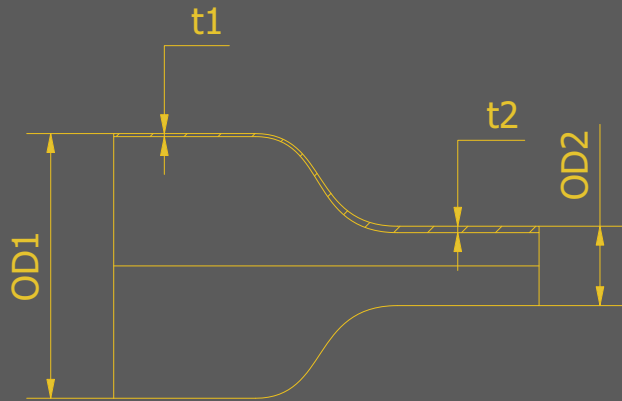

Sealing of connection zones and various joints in permanent DCP anchors and micropiles is of great importance to achieve a true encapsulation of the body of anchors and soil nails in plastic sheathing.

For this purpose, heat shrinking tubing is an ideal product. ELEBOR offers a range of UV resistant high-shrinkage ratio heat shrink tubing that matches the sizes required for the various DCP anchors, nails and micropiles.

The product has an additional adhesive lining, which melts when the tubing is heated and shrunk, guaranteeing a seamless, waterproof and UV resistant encapsulation.

- Operating temperature : +55 up to +110°C
- Minimum full recovery temperature : +120°C
- UV resistant
- Halogen-free

Model	Part Nr.	Tubing OD		Shrinking ratio	Wall thickness after heating t2 (min) mm	Packaging pieces
		as supplied OD1 (min) mm	after heating OD2 (max) mm			
75 / 22	TT-SS-075/022-THS	75	22	3:1	2,7	1 m
95 / 25	TT-SS-095/025-THS	95	25	3:1	2,8	1 m
115 / 35	TT-SS-115/035-THS	115	35	3:1	3,4	1 m
140 / 42	TT-SS-140/042-THS	140	42	3:1	3,4	1 m

Other sizes available upon request

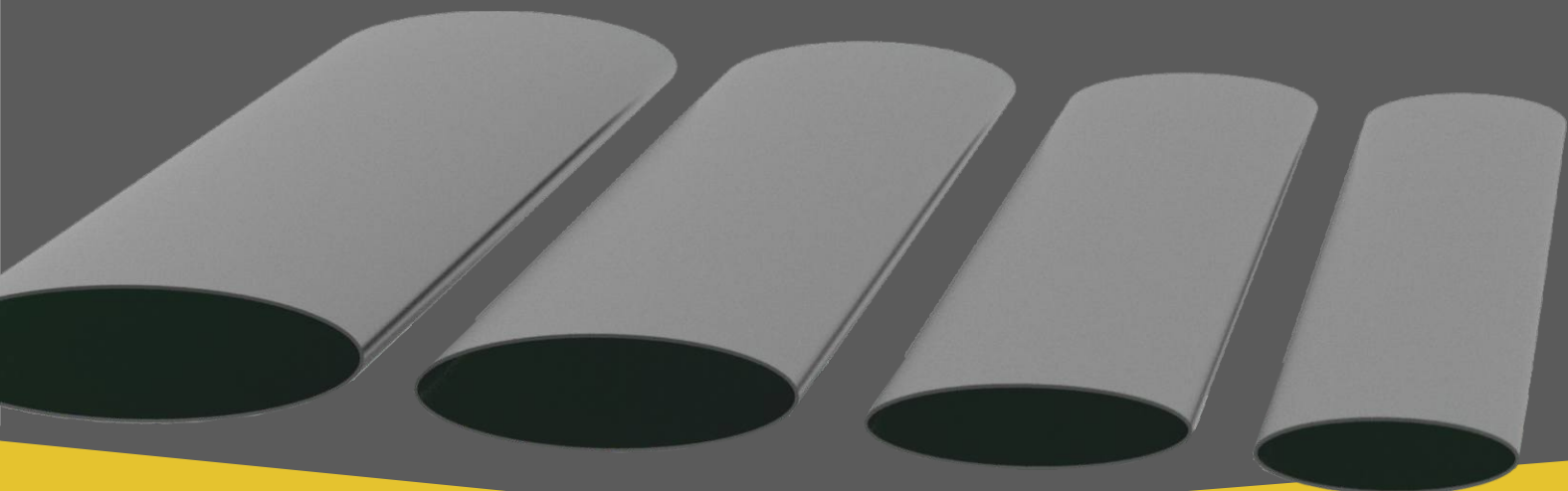

ELEBAR™-G system components

Smooth sheathing

Externally smooth plastic tubes can also be used for the encapsulating sections of the body of provisional or permanent anchors and soil nails. However, smooth sheaths are mainly used to formulate the tensioned part of ground anchors also known as the “free-length” .

DUROTENE® Low Density Polyethylene (LDPE) smooth sheaths are available in various wall thicknesses and diameters to match entire range of corrugated sheaths.

DUROTENE® smooth sheaths

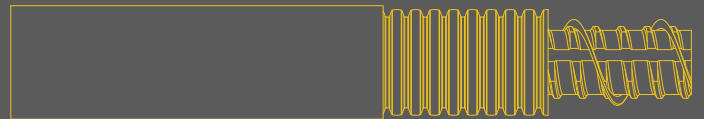

Size	OD mm	ID mm	Thickenss mm	Packaging
42,6 / 45,0	28,0	45,0	1,2	roll
47,6 / 50,0	55,0	50,0	1,2	roll
52,6 / 55,0	57,0	55,0	1,2	roll
51,0 / 55,0	65,0	55,0	2,0	roll
57,0 / 60,0	70,0	60,0	1,5	roll
62,0 / 65,0	85,0	65,0	1,5	roll
67,0 / 70,0	100,0	70,0	1,5	roll
72,0 / 75,0	114,0	75,0	1,5	roll
71,0 / 75,0	114,0	75,0	2,0	roll
81,4 / 85,0	117,0	85,0	1,8	roll
87,4 / 91,0	117,0	91,0	1,8	roll
92,4 / 96,0	114,0	96,0	1,8	roll
104,0 / 108,0	117,0	108,0	2,0	roll
117,0 / 121,0	114,0	121,0	2,0	roll

* Other sizes available upon request

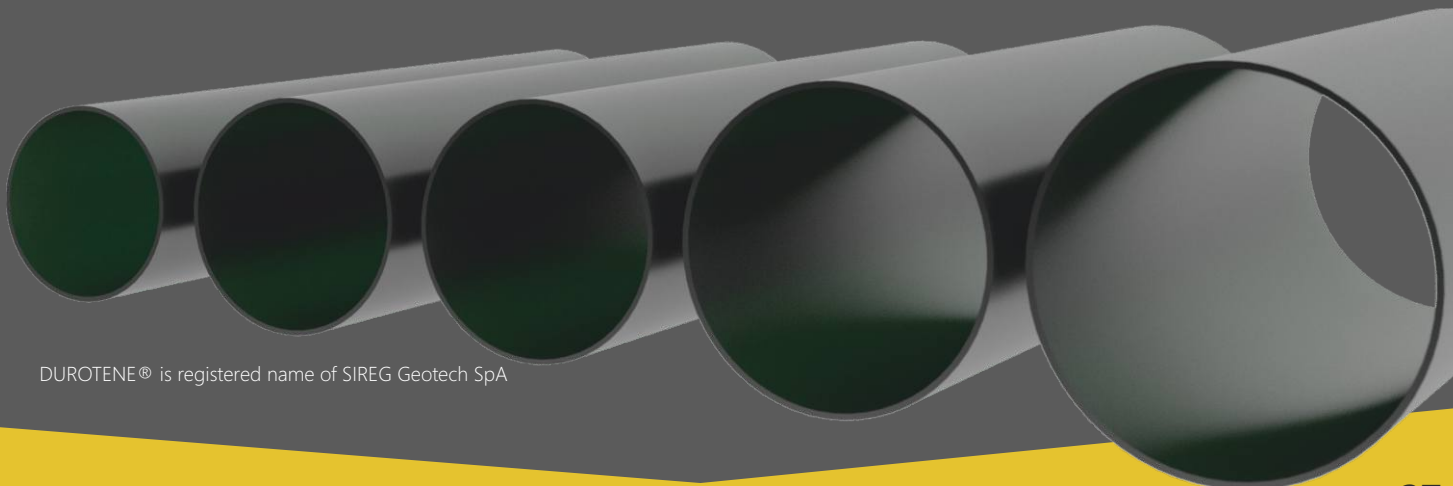
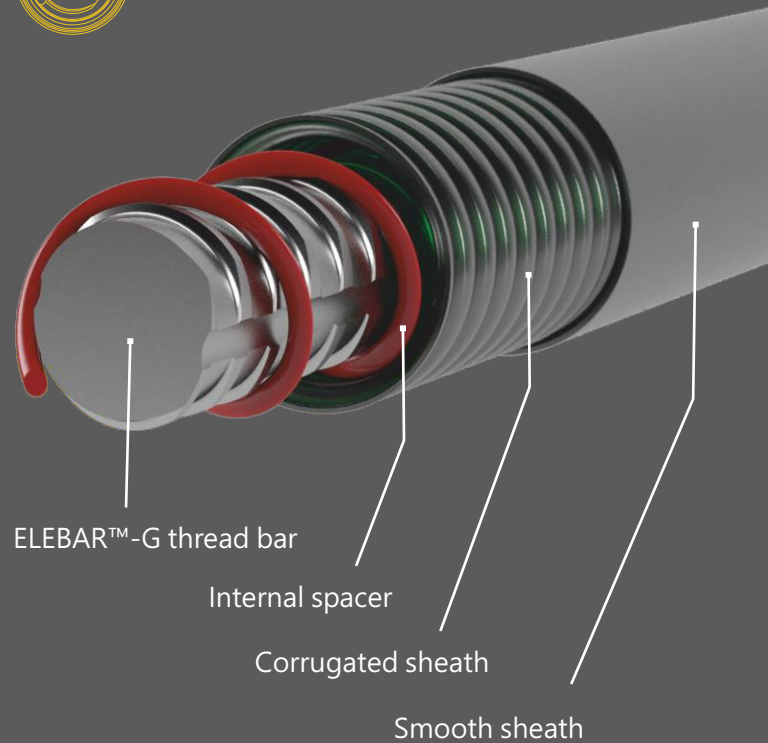
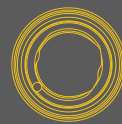

DUROTENE® is registered name of SIREG Geotech SpA

ELEBAR™-G system components

External centralizers

Plastic basket type centralizers

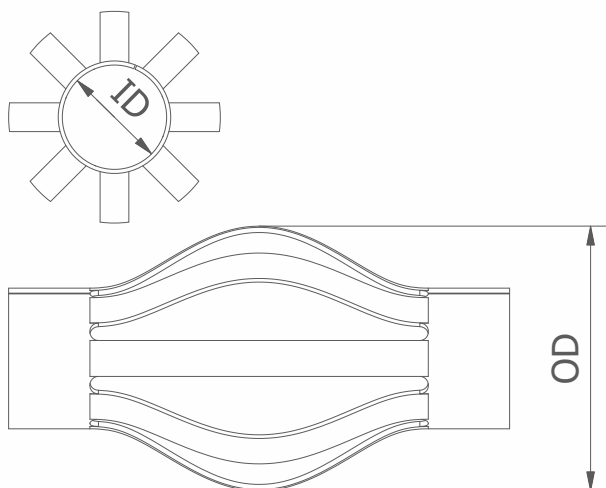

Part Nr.	ID mm	OD range mm
DSP-A215-****	21,5	40 - 75
DSP-A285-****	28,5	75 - 135
DSP-A340-****	34,0	75 - 135
DSP-A425-****	42,5	90 - 150
DSP-A490-****	49,0	90 - 150
DSP-A570-****	57,0	100 - 160
DSP-A690-****	69,0	100 - 160
DSP-A750-****	75,0	120 - 180
DSP-A846-****	84,6	120 - 180
DSP-A900-****	90,0	140 - 200
DSP-A103-****	103,5	140 - 200
DSP-A118-****	118,0	160 - 220
DSP-A134-****	134,0	180 - 250
DSP-A153-****	153,5	200 - 270

**** : Centralizing diameter in millimeters

Reinforcement centralization inside the bore-hole is one of the key elements to ensure the high quality of a ground anchoring job. The use of centralizers is thus indispensable regardless of whether the aim is to achieve a provisional or a permanent ground anchor.

Centralizers are essential components for any type of rock bolting and ground anchoring work and shouldn't be considered as optional accessories.

Centralizers offer an even cement grout coverage around the reinforcement which is important to achieve the highest levels of load transfers between the surrounding ground and the thread bar in respect to the guidelines of the European Standard EN 1537:2013.

Basket type centralizers, also known as lantern centralizers, are the most common type for use with ground anchors and rock bolts. They are frequently referred to as "external centralizers" to distinguish them from the centralizers that are used internally of the corrugated sheath in DCP ground anchors and micropiles.

Basket type centralizers are made from PVC tubing deformed to the particular shape resembling a basket. The smooth curvy shape offers an excellent slide of the anchor inside the bore-hole making insertion of the assembled anchor an easy process. At the same time the curved wings offer a degree of flexibility so that centralizers can adapt to the bore-hole size and wall irregularities. The centralizers are supplied with a longitudinal cut slot to aid fitment without being necessary to slide them from the anchor end.

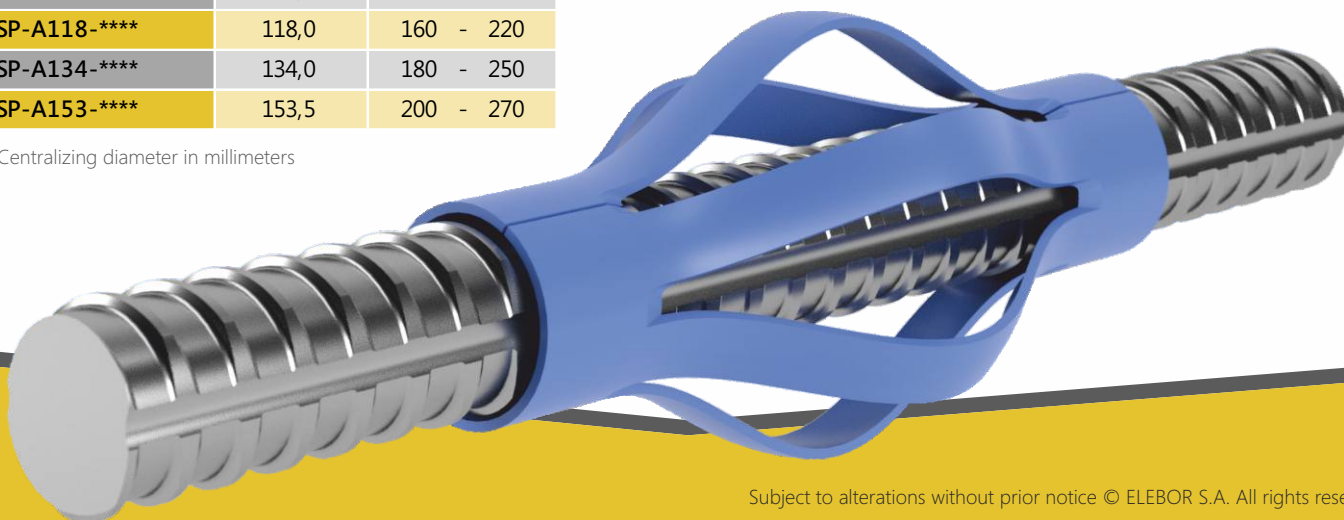

ELEBAR™-G system components

Internal & external centralizers

Various types of plastic fittings are available to centralize the ELEBAR™-G thread bar inside the corrugated sheath in DCP ground anchors, soil nails or micropiles. These include a series of DUROTENE® plastic spacers as well as various size of PE cords which are coiled around the thread bar.

Internal centralizers are a necessary component to achieve an even cement grout coverage around the thread bar in respect to the guidelines of the the European Standard EN 1537:2013.

Internal centralizers

DUROTENE® plastic spacer
used as internal spacer

Internal spacer (PE cord)

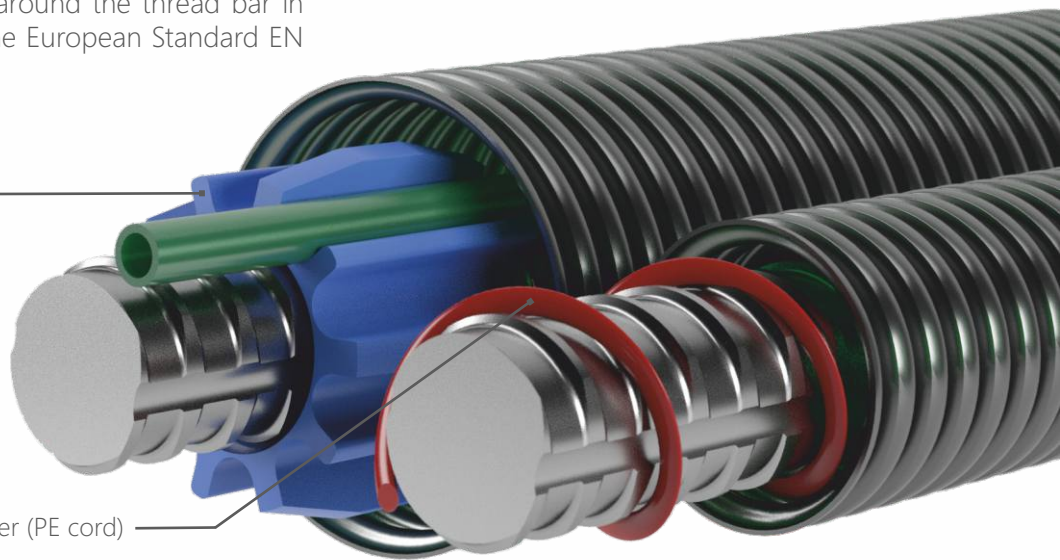

Part Nr.	Centering height	Length x Width
	mm	mm
DSP-CENTR10 ^[1]	10	-
DSP-CENTR20-220 ^[2]	20	220 x 60
DSP-CENTR20-270 ^[2]	20	270 x 60
DSP-CENTR27-220 ^[2]	27	220 x 80
DSP-CENTR27-270 ^[2]	27	270 x 80
DSP-CENTR27-310 ^[2]	27	310 x 80
DSP-CENTR40-320 ^[2]	40	320 x 80

Wrapping type external centralizers

[1] : Comprised of two halves
[2] : Flexible wrapping strip

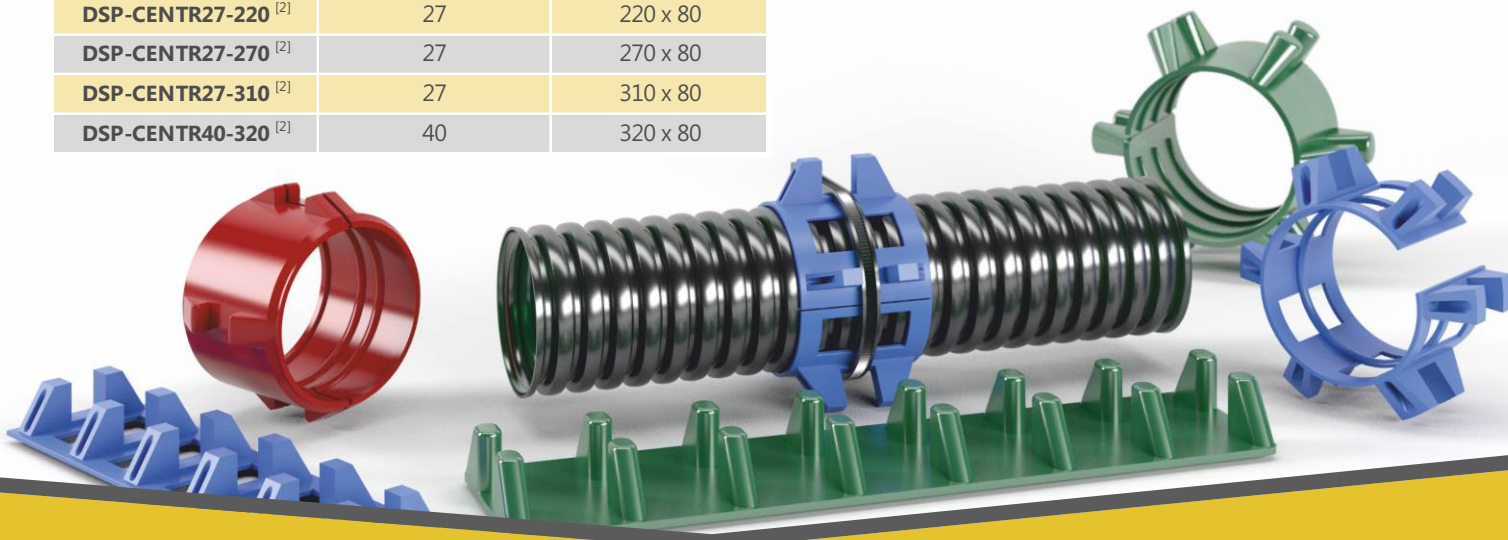

RocLoc™ resin cartridges for resin fixed rock-bolts



RocLoc™ resin capsules have a cylindrical shape and consist of two (2) separate compartments containing a resin mastic and a catalyst paste. The two (2) components are vacuum sealed in a polyester film. A special plastic cap with radial projected ends (known as “parachute”) may be fitted to one of the cartridge tip and acts as a retaining element preventing the capsule from sliding out of the bore-hole.

The choice of capsules depends on the diameter of the rock bolt and bore-hole. An annular gap of 3 mm is ideal to permit rupture of the capsule membrane and to ensure adequate mixing of the two components.

The hardening time (hold time) depends on the resin type, the temperature as well as to the energy given to the system while the rock-bolt is inserted into the bore-hole.

The main advantages of resin cartridges are:

- High load transmission due to high bonding strength
- Short setting times allow fast bearing support of the rock-bolt and overhead roof bolting
- Ease and speed of installation
- Simple and safe handling
- Full length encapsulation or point anchoring possible
- Suitable for automated installations due to possibility of pneumatic firing
- Capsules with different setting times, lengths and diameters are available to cover a wide range of applications.

RocLoc™ is registered name of RSC Ekusasa Mining Joint Venture (Pty) Ltd



Gel Time sec	Spin Time sec	Hold Time sec	Colour Code
15	7	8	Purple
20	8	12	Black
30	10	20	Red
60	15	45	Green
120	20	100	Blue
5/10 min	20	10 min	Yellow

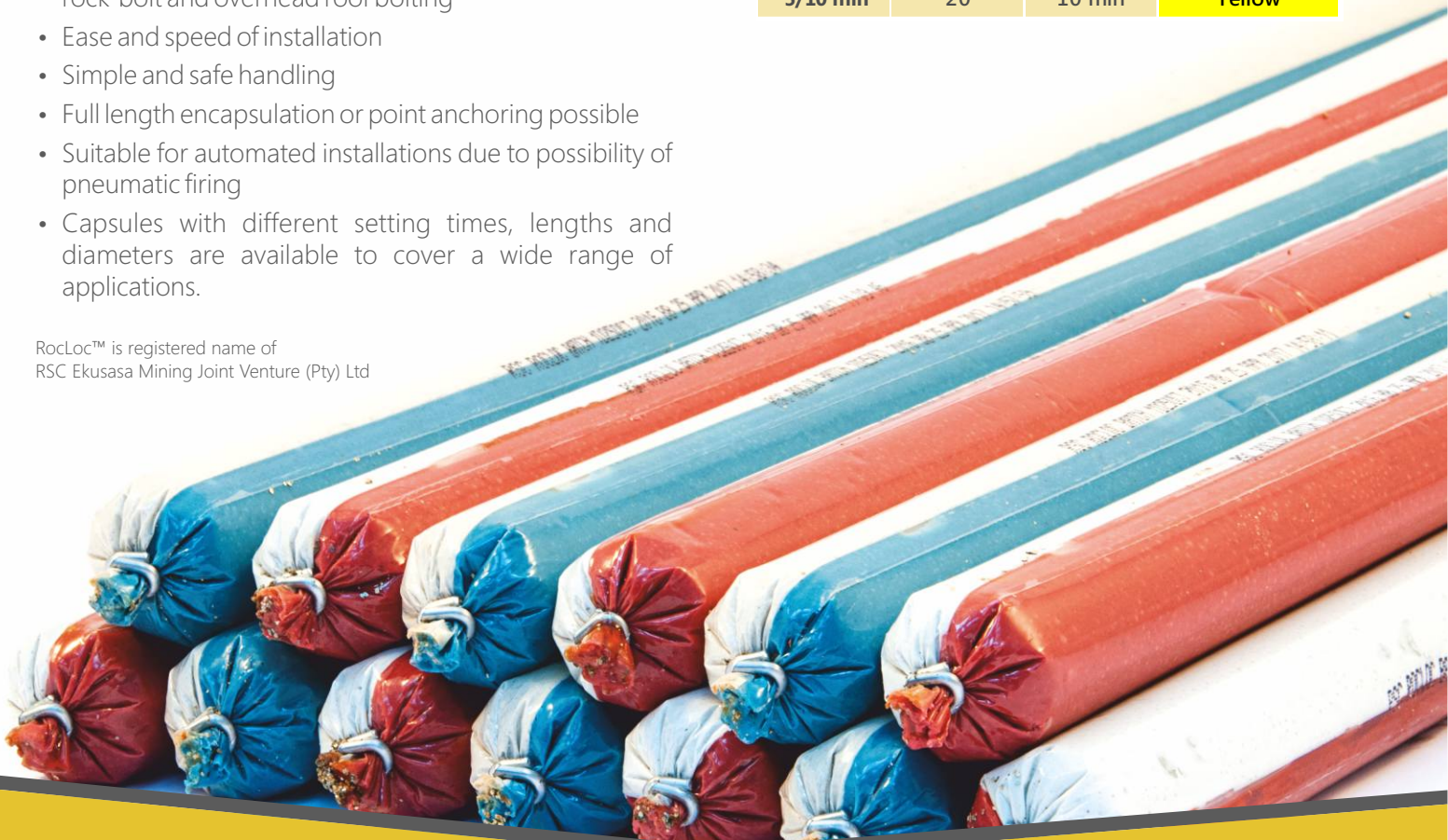

ELEBAR™-G system components resin rock bolt installation tooling

Various kinds of special tooling is available for manual, semi-automatic or for fully mechanized resin rock-bolt installations.

Resin rock-bolt installations, as explained in page 12, require initially the spinning of the ELEBAR™-G thread-bar to aid the mixing of the 2 capsule constituents. Installation finishes with torque tensioning the hex nut.

Above installation steps can be achieved with two separate tools, (a) the spinning tool and, (b) the nut torque tensioning tool. Spinning tools feature a square socket that engages easily the tip of the thread-bar without being necessary to screw onto the thread. This is attributed to the special ELEBAR™-G thread-bar shape with the interrupted thread crest coil and the 2-sided flattened profile.

The range of spinning tools include:

- tools for hand-held drills compatible with any industry tool shank style like SDS, SDS Plus, SDS Max,
- tools for percussion rotary jack leg rock-drills, with hex shank styles like 7/8" x 4.1/2" and others,
- tools with threaded connections like R25, R32, R38, T38, T45 or T51 for pneumatic or hydraulic drifters, etc.

Conventional nut torque tensioning tools are available and presented in page 34.

ELEBOR S.A. offer also a specially designed ALL-IN-ONE installation tool that is capable to spin the ELEBAR™-G thread-bar and subsequently to torque tension the nut. This combi dolley tool offer fully mechanized resin rock bolt installations without being necessary to change tools or to introduce special features on the nut (i.e. thread distortion, pin-stop etc.) or on the thread bar end-tip (i.e. thread distortion, spot welding bead etc.).

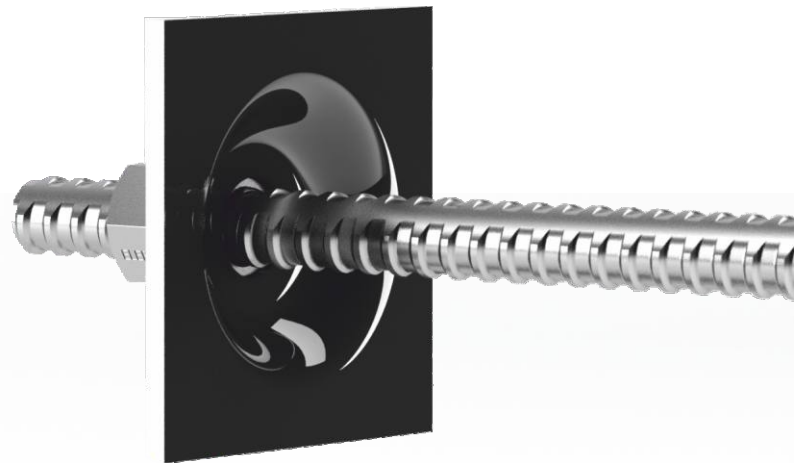

Combo dolleys

Spinning tools



ELEBAR™-G system accessories

Grout perfo socks

ELEBAR™ Grout Perfo Sock is produced from a specially formulated geo sock and acts as grout retainer around rock bolts and ground anchors to prevent loss of grout to the surroundings. The grout sock ensures the necessary grout volume in the bore hole required to guarantee the desired performance of the rock bolt or ground anchor.

The ELEBAR™ Grout Perfo Socks are specially designed and weaved so that they are partially permeable by the grout, thus enabling the grout to bleed through to the surroundings but simultaneously to expand onto the rock wall and harden into the shape of the drill hole.

Grout socks are especially useful for bolting applications in which there is a high risk of uncontrolled grout escape as for example in fissured rock or in weak masonry walls. Trials have shown that the interlocking effect and bonding at the grout and rock interface is not affected due to the presence of the sock.

ELEBAR™ Grout Perfo Socks are highly elastic. The tubular rib-knit fabric sock is capable of expansion up to 500%. For example the 70mm (S07) model can expand up to approximately 500mm.

The ELEBAR™ Grout Perfo Socks are available in Single (type S) and Double (type D) weaving versions and are in rolls.

Size Code	Part Nr.	Lay down width mm
S 4	GREFS04R60	40
S 7	GREFS07R60	70
S 8	GREFS08R60	80
S 9	GREFS09R60	90
S 10	GREFS10R60	100
S 12	GREFS12R60	120
D 8	GREFD08R60	80
D 9	GREFD09R60	90
D 10	GREFD10R60	100
D 12	GREFD12R60	120

S : Single knit socks
D : Double knit socks

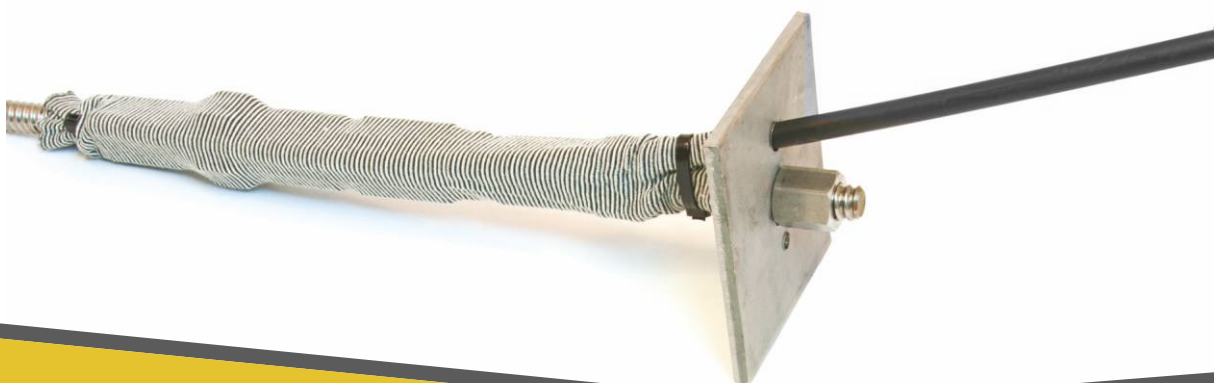



Illustrated model : CG-542A Rock Bolt & Cable Grouter

ChemGrout® grouting pumps & plants

ELEBOR is the exclusive distributor of U.S. ChemGrout®.

A complete line of grouting pumps or complete grouting plants are available to satisfy the most demanding grouting operation task.

Various types and sizes of grout pumps are available to cover a wide range of discharge pressures and pump grout volumes.

The range of pumps includes :

- piston grout pumps,
- progressive cavity pumps,
- double acting plunger pumps.

DM21/11 portable grout pump

Portable, compact electric driven injection screw pump with the following features :

- on-board electrical panel
- 5.5kW (7.5HP) electric motor
- depending on chosen rotor/stator set, flow rates from 20 to 60 liter per minute can be achieved
- depending on injection material characteristics, pumping distances up to 60m can be achieved
- hopper loading capacity of 60 kg
- unit is supplied with complete water system
- discharge valve with pressure gauge
- unit is supplied with 22m cable & remote control
- supplied with 20m grouting hose
- CE certified unit



ELEBAR™-G system installation tooling

Rock bolt nut torque wrenches

ELEBOR S.A. offers a range of heavy duty, industrial use, torque wrenches suitable for torque tensioning ELEBAR™-G thread-bar anchors and rock bolts. The list of tools includes a complete range of extended hexagonal sockets to suit the various types and sizes of ELEBAR™-G nuts.

The equipment is available for sale or rental.

Range Nm	Part Nr.	Length mm	Weight kg
150 - 700	TT-NOR-TW4R	910	6,3
200 - 800	TT-NOR-TW4AR	1.250	6,4
300 - 1.000	TT-NOR-TW5R	1.475	7,3
700 - 1.500	TT-NOR-TW5AR	1.475	10,4
900 - 2.000	TT-NOR-TW6R	1.920	13,0

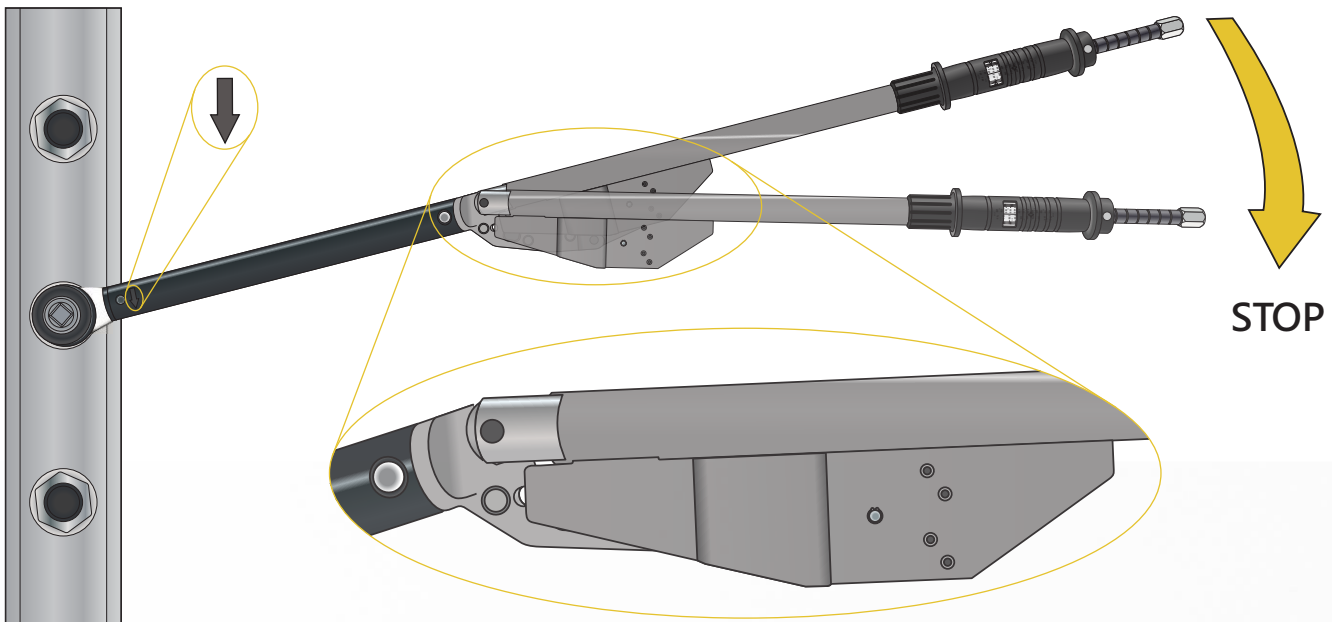

ELEBAR™-G testing equipment

Pull-testing & Tensioning equipment

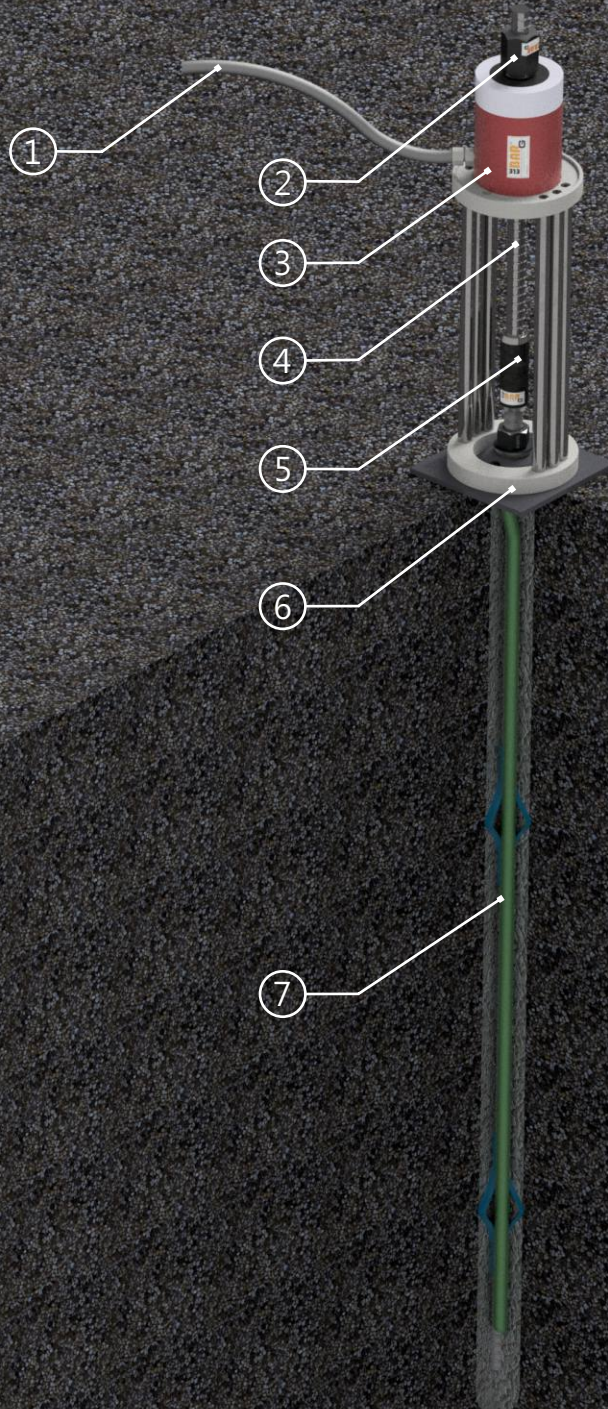

A complete range of testing apparatus is available to perform pull-out tests in all types and sizes of installed ELEBAR™-G thread bar rock-bolts, anchors or micropiles. Same systems can be employed for pre-stressing anchor systems.

The main system components are:

- a hollow hydraulic cylinder (size matching the capacity of the bolt to be tested)
- a hydraulic pump (manual operated or electric driven)
- a manometer for monitoring the applied load
- a hydraulic hose with quick connection fittings
- a resting base bolted to the hydraulic cylinder providing the necessary room for rock-bolt elongation during the pull-out testing
- a set of accessories including an extension rod of suitable length, test coupler and nuts.

Cylinder capacity tons	Model Name	Center hole mm	Piston Stroke mm	Metric tons at 700 bar mm	Weight kg
30	RH302	32,9	63,5	28,8	11,6
30	RH306A	32,5	149,2	28,8	9,9
30	RH306	32,5	152,4	28,8	17,7
50	RH503	42,5	76,2	49,3	21,2
60	RH603	54,0	76,2	55,9	27,2
60	RH606	54,0	152,4	55,9	35,4
100	RH1003	79,4	76,2	93,5	52,2

* Other sizes of cylinders are available both in single action and double action versions.
A : Aluminium version

1. High pressure hose
2. Locking nut
3. Hollow hydraulic cylinder
4. ELEBAR™ -G extension bar
5. ELEBAR™ -G coupler
6. Modular ELEBAR™ cylinder resting base
7. ELEBAR™ -G installed rock-bolt



ELEBOR S.A.

1 Pindou str. & 17 Poseidonos ave.,
GR-183 44 Moschato

Athens, Hellas

Tel.: +30 210 94 00 006

Fax: +30 210 94 00 566

e-mail: info@elebor.gr

www.elebor.gr

